

# HEWLETT-PACKARD JOURNAL

JUNE 1986

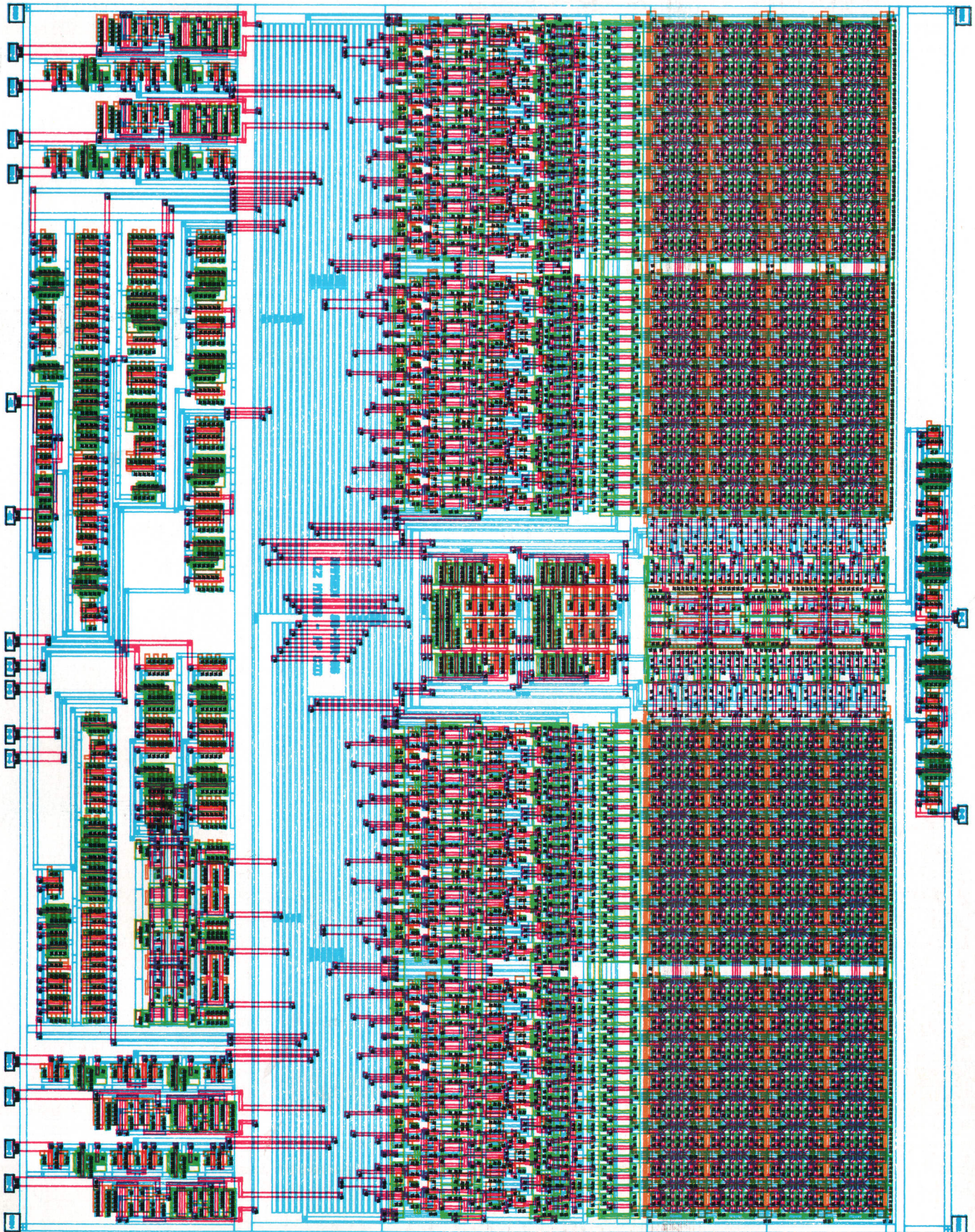

# HEWLETT-PACKARD JOURNAL

June 1986 Volume 37 • Number 6

## Articles

---

**4 Integrated Circuit Procedural Language**, by Jeffrey A. Lewis, Andrew A. Berlin, Allan J. Kuchinsky, and Paul K. Yip *This in-house Lisp-based VLSI design tool accommodates different fabrication processes and functional cells with variable characteristics.*

**8 Knowledge-Assisted Design and the Area Estimation Assistant**

---

**11 Software Development for Just-in-Time Manufacturing Planning and Control**, by Raj K. Bhargava, Teri L. Lombardi, Alvina Y. Nishimoto, and Robert A. Passell *This software product provides streamlined management information for the just-in-time environment.*

**13 Comparing Manufacturing Methods**

## 18 Authors

---

**20 The Role of Doppler Ultrasound in Cardiac Diagnosis**, by Raymond G. O'Connell, Jr. *Data about blood flow anomalies can be obtained by observing the shift in frequency of ultrasonic imaging pulse echoes.*

---

**26 Doppler Effect: History and Theory**, by Paul A. Magnin *The shift in the frequency of sound for moving sources and/or listeners is described with its application for medical analysis.*

**27 Johann Christian Doppler**

---

**31 Power and Intensity Measurements for Ultrasonic Doppler Imaging Systems**, by James Chen *Carefully controlling the acoustic energy transmitted into the human body requires accurate analysis methods.*

---

**35 Extraction of Blood Flow Information Using Doppler-Shifted Ultrasound**, by Leslie I. Halberg and Karl E. Thiele *Frequency shifts in ultrasonic echoes are detected by means of specially designed filters and a quadrature sampler.*

**37 Continuous-Wave Doppler Board**

**39 Observation of Blood Flow and Doppler Sample Volume**

---

**41 Modifying an Ultrasound Imaging Scanner for Doppler Measurements**, by Sydney M. Karp *Changes in timing, more precise focusing, processing enhancements, and power-limiting software had to be developed.*

---

**45 Digital Processing Chain for a Doppler Ultrasound Subsystem**, by Barry F. Hunt, Steven C. Leavitt, and David C. Hempstead *Time-domain quadrature samples are converted into a gray-scale spectral frequency display using a fast Fourier transform, moment calculations, and digital filtering.*

---

Editor, Richard P. Dolan • Associate Editor, Business Manager, Kenneth A. Shaw • Assistant Editor, Nancy R. Teater • Art Director, Photographer, Arvid A. Danielson • Support Supervisor, Susan E. Wright  
Illustrator, Nancy Contreras • Administrative Services, Typography, Anne S. LoPresti • European Production Supervisor, Michael Zandwijken

---

## In this Issue

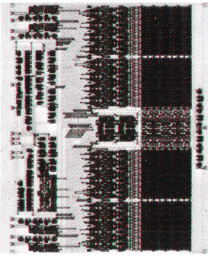

The integrated circuit artwork on our cover this month was drawn automatically by what's sometimes called a silicon compiler. As the authors of the article on page 4 explain, "The process of silicon compilation is analogous to the role of high-level language compilers in software engineering. The designer specifies the behavior and/or structure of the desired circuit in a high-level language. Working from the high-level specifications, the silicon compiler generates the detailed circuitry programmatically. This not only is faster than design by hand, but also allows system designers not familiar with IC design techniques to create an IC chip." The subject of the article is a high-level language used in-house by HP designers to specify a chip. Called ICPL, or Integrated Circuit Procedural Language, it's a Lisp-based language similar to MIT's DPL.

About as new as silicon compilation is just-in-time manufacturing, the technique pioneered in Japan and now spreading throughout the world. An estimated 250 plants in the U.S.A. have implemented it and most large manufacturing companies are testing the concept. The article on page 11 describes the design of HP JIT, an HP software product intended to be used by just-in-time manufacturers for material requirements planning and production control. Worthy of note are the methods used by the software designers to develop a package with no examples or standards to use for guidance. Working with HP manufacturing divisions starting up just-in-time facilities, the software designers tried out ideas using throwaway prototypes before finally writing specifications and code.

The remaining six articles in this issue discuss a Doppler enhancement for HP's medical ultrasound imaging system, first featured in these pages in October and December of 1983. In ultrasound imaging, high-frequency sound waves are bounced off structures inside the body, letting physicians see the body's inner workings without surgery or health risk to the patient. The Doppler system augments the normal ultrasound image by adding information about the velocity of blood flow and organ movements. On page 20, Ray O'Connell discusses the role of Doppler ultrasound in cardiac diagnosis. On page 26, Paul Magnin presents Doppler history and theory and tells us a little about Johann Doppler (page 27). The articles on pages 35, 41, and 45 describe the design of the HP Doppler system, which can be added easily to any HP ultrasound imaging system. On page 31, James Chen tells how ultrasound power and intensity are measured to ensure patient safety.

-R. P. Dolan  
Editor

---

## What's Ahead

Next month's issue will describe the design of HP's portable computer family—The Portable and Portable Plus. Memory management, low-power operation, I/O and data communications, liquid-crystal display control, and creation of custom plug-in ROMs are some of the topics. Also featured will be an article about the latest capabilities of HP-UX, HP's version of the UNIX™ operating system, now available on HP 9000 Series 300 Computers. We'll also have the design story of the HP 4971S, a protocol analyzer for local area network installation and troubleshooting.

# Integrated Circuit Procedural Language

*ICPL is a Lisp-embedded procedural layout language for VLSI design. Circuit design in ICPL involves writing and working with programs that resemble procedures, take parameters, and can use the full symbolic programming power of Lisp. This allows circuit designers to write high-level software that procedurally builds ICs.*

by Jeffrey A. Lewis, Andrew A. Berlin, Allan J. Kuchinsky, and Paul K. Yip

**I**N RECENT YEARS, the design and fabrication of electronic circuits on microchips has achieved the level of very large-scale integration (VLSI). It isn't uncommon today for a single chip to contain hundreds of thousands of transistor devices, and we are beginning to see designs where the component count exceeds one million devices. With this dramatic increase in chip density comes an equally pronounced increase in the complexity of the circuit designs, resulting in a design bottleneck in the transformation of functional specifications into manufactured products.

Conventional approaches to integrated circuit design view circuits as a collection of rectangular regions—the geometrical patterns used to define the devices on an IC chip. Circuit synthesis traditionally has been boiled down to the art of handcrafting this large collection of rectangles, most recently accomplished through the use of computer-based graphic editing. This manual approach is highly tedious and error-prone when dealing with hundreds of thousands of rectangles, where one misplaced or undersized rectangle can cause catastrophic malfunction in the circuit. In addition, the designer must constantly juggle many conflicting criteria such as total chip area, power consumption, and signal delay. As the number of components grows, these interrelationships become exponentially more complex. This complexity causes many designers to leverage their designs by using as many pieces of old designs as possible. But since integrated circuit processes are changing so rapidly, very few old designs can be used in new ones. The same type of adder, for example, must be redesigned for every fabrication process it is used in (see Fig. 1). Clearly, more automated mechanisms for designing circuits are needed.

## Silicon Compilation

Silicon compilation is a burgeoning subdiscipline of computer-aided design (CAD) that addresses the problem of managing VLSI complexity by automatically synthesizing complex designs from high-level architectural descriptions. Various referred to as systems for silicon assembly, module generation, macrocell assembly, or automated layout, silicon compilation tools come in many variations. What they have in common is that they raise the level of abstraction at which the chip designer operates so that the designer is more insulated from the complexity and vari-

ation in lower levels. The designer is freed from performing the tedious and error-prone tasks required by detailed manual layout of rectangles. Exploration of alternative architectures is simplified, making it easier to create more efficient and cost-effective designs.

The process of silicon compilation is analogous to the role of high-level language compilers in software engineering. The designer specifies the behavior and/or structure of the desired circuit in a high-level language. Working from the high-level specifications, the silicon compiler generates the detailed circuitry programmatically. This is not only faster than design by hand, but also allows system designers not familiar with IC design techniques to create an IC chip. Silicon compilation ultimately makes chip design accessible to every circuit design engineer.

One popular mechanism by which silicon compilation tools generate circuit artwork programmatically is known as procedural layout. In the procedural layout paradigm, a chip design resembles a software program. Circuit parts resemble subroutines, take parameters, and can be "called" by other parts. Thus, smaller parts can be hierarchically built into larger parts, freeing the designer to concentrate on higher-level issues. This provides a high degree of design leverage. Parts generated programmatically are also less prone to error than parts drawn by hand. One reason is that values such as the size of a component or the spacing between two components can be expressed as fabrication process variables rather than by hardcoded numbers. Designers can also specify a part's location relative to other parts.

We chose the Lisp programming language as a basis for silicon compilation and procedural layout design tools for several reasons. After more than 30 years of language and application development, the Lisp environment is unequaled in providing a powerful set of editing and debugging aids that translates into a friendly and extensible user interface. Lisp is symbolic, meaning that it naturally captures the way in which "real world" knowledge is represented for problem solving. The interactive nature of Lisp allows for a rich debugging environment for development of both procedural layout design tools and the circuit designs that use them. Dynamic linking and loading provide a high degree of incrementalism for exploratory programming, and Lisp can be compiled for production-quality programs.

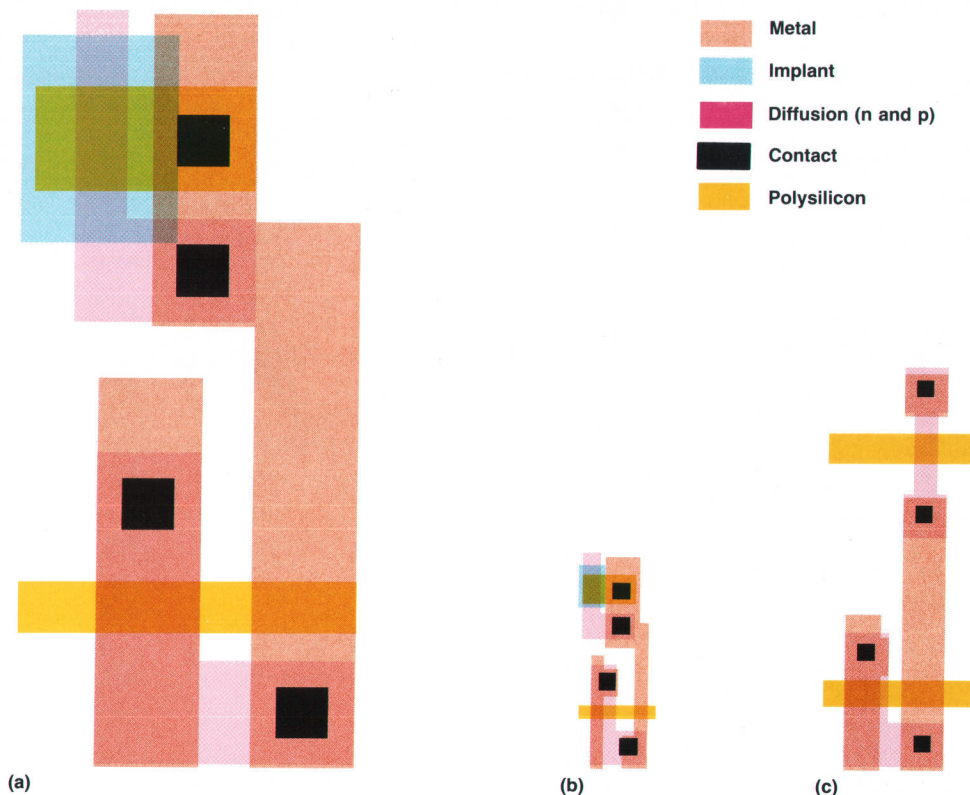

**Fig. 1.** As a process technology changes, the placement and size of the rectangular elements forming a circuit element must be altered to achieve similar performance. (a) NMOS-C cell. (b) Equivalent NMOS III cell. (c) Similar CMOS-H cell. All cells were built using the same ICPL code and different fabrication process libraries.

Furthermore, the Lisp environment is the natural foundation for communication between CAD applications and powerful Lisp-based expert systems tools. Any tool that is embedded in Lisp can be invoked by any other to solve a partial problem or can be used as the top-level design system. Thus, CAD functions can be used within rules and knowledge-base queries can be called from within CAD functions (see box on page 8). In addition to expert system capability, other advanced programming techniques such as object-oriented and data-driven programming are readily accessible.

Finally, the Lisp environment provides extensibility of both the tool set and the knowledge base to drive it. Extending programs in conventional programming languages requires recompiling a fairly large world, or providing a program that covers all possibilities by run-time tests. This is not necessary in Lisp, where functions are dynamically recompilable and relinkable.

### ICPL

HP's Integrated Circuit Procedural Language, or ICPL, is a Lisp-based language that can be used by circuit designers within HP to write programs that describe an integrated circuit's layout. It is based on the Design Procedure Language (DPL) developed at MIT's Artificial Intelligence Laboratory<sup>1</sup> and has been modified both in functionality and structure to run on HP hardware and address the needs of HP designers. Fundamentally, an ICPL designer writes a program that describes how to build the layout and connectivity of a part rather than drawing it graphically. This allows a user's cell definitions to be compiled, parsed by the Lisp reader, and have embedded Lisp constructs like

any other Lisp dialect.

Simply being a language is not ICPL's strongest point. Through the use of the symbolic programming capabilities of ICPL, a designer can specify far more than a simple geometric layout of a circuit. Cell libraries written in ICPL have a significant advantage over traditional graphically created libraries in that an ICPL cell can take parameters like any other procedure to alter its functionality. For example, a buffer circuit can take as a parameter the capacitive load it must be capable of driving and the speed at which it must run, and then size itself to guarantee proper operation for a particular application. Parameters can also be used to create many variations on a particular design. For example, a single register cell is capable of incrementally adding the circuitry necessary to read to or write from additional buses. A single cell with variable characteristics eliminates the need for graphically generating the hundreds of traditional cells that correspond to every possible combination of parameters.

The physical constraints imposed by a process technology are captured symbolically in ICPL via Lisp functions that describe geometrical relations between parts. For example:

```
(min-spacing 'poly 'diffusion)
```

will return a number that represents the minimum separation between a rectangle on the polysilicon layer of an IC chip and a rectangle on the chip's diffusion layer. In traditional design methodologies, a designer would have the poly-diffusion separation rule memorized, and would graphically separate the rectangles. In ICPL, a designer simply includes a Lisp form that tells the system to separate

the two rectangles:

```
(align (>> some-poly-rectangle)
 (>> center-left some-poly-rectangle)
 (pt-to-right
 (>> center-right some-diffusion-rectangle)
 (min-spacing 'poly 'diffusion)))
```

The Lisp form shown above would move some-poly-rectangle such that its left center is to the right of some-diffusion-rectangle by the minimum spacing between poly and diffusion. ICPL captures the designer's reason for separating the two rectangles, thus allowing the design to withstand minor changes in the design rules of a process. If a cell is laid out graphically and a process change occurs affecting the minimum separation, the designer must graphically move the rectangles to achieve the new minimum separation. In most cases, there is not enough room to move a rectangle to achieve a design rule change without hitting a new rectangle and consequently having to move it and its neighbors. These changes can propagate outward until everything in the cell must be moved. Because of their resistance to change, graphic layouts tend to be discarded when an IC fabrication process changes, thereby eliminating the ability to reuse previous design work. Although it may take a little longer to design a cell programmatically using ICPL, such an effort is greatly rewarded by the ease with which design changes can be achieved, and by the ability to use a successful design for other projects.

ICPL incorporates a design management system to provide an environment in which rectangles can be placed, wires can be easily run, and a library of hierarchically organized cells can be maintained. Connectivity informa-

tion is maintained as it is declared by the designer, permitting integration of routing and automatic placement utilities. Parameters are passed on a keyword-value basis, defaulting to specified values if they are not supplied by the caller. For example, consider the following ICPL description of an NMOS inverter:

```
(deflayout INVERTER ((pullup-length *min-pullup-length*)
 (pullup-width *min-gate-size*)
 (pulldown-length *min-gate-size*)
 (pulldown-width *min-gate-size*))
 (part 'pullup 'standard-pullup
 (channel-length (>> pullup-length))
 (channel-width (>> pullup-width)))
 (part 'pulldown 'rectangular-fet
 (channel-length (>> pulldown-length))
 (channel-width (>> pulldown-width))
 (top-center
 (>> bottom-center diffusion-connection pullup)))
 )
```

It shows one other powerful feature of ICPL—other designers can look at the code and understand why things were done in a certain way. For example, an explicit align statement will show that there is some sort of spatial relationship between two parts.

Another thing to notice about the above inverter example is the procedural style of the deflayout. A deflayout is analogous to a Lisp defun or Pascal procedure definition because it can take parameters and gives a sequence of steps to perform. The inverter takes four parameters—pullup-length, pullup-width, pulldown-length, and pulldown-width—which all have default values taken directly from the fabrication process

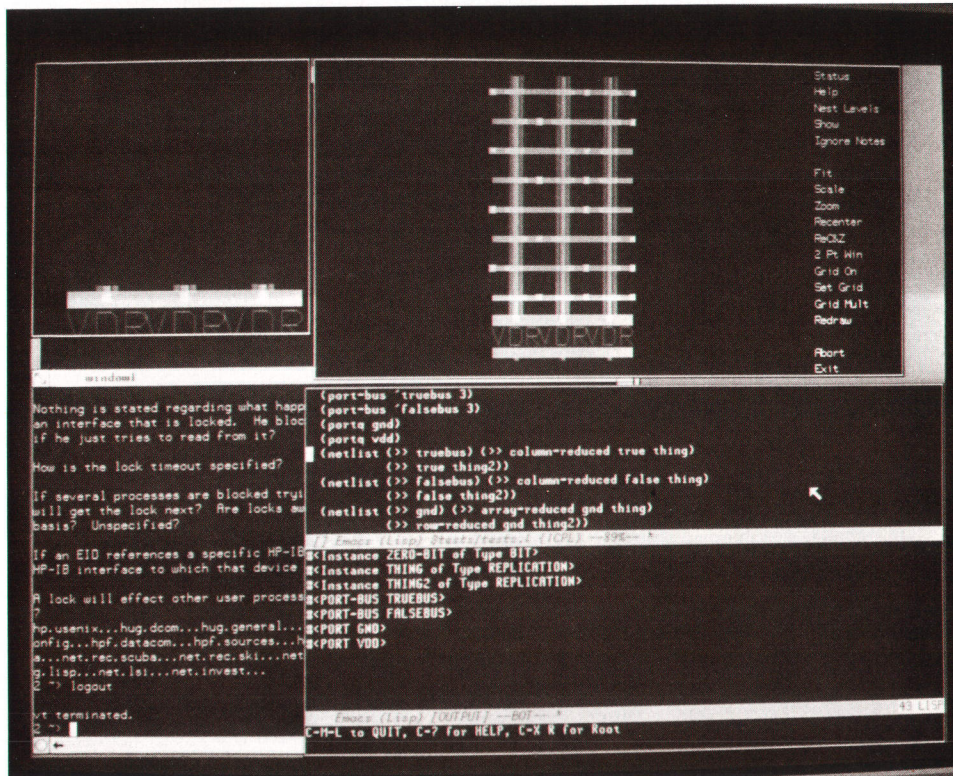

Fig. 2. ICPL display showing design elements which can be addressed and changed graphically using a mouse.

design rules. If a parameter is not passed to the inverter code, then the default value will be used. Inside the `deflayout` we have two part calls to `deflayouts` that have been previously defined—`standard-pullup` and `rectangular-fet`. Since the four parameters to the inverter code actually refer to the transistor sizes of the constituent parts, we must pass these parameters down to the pullup and pulldown code actually responsible for sizing the transistors. Finally, notice that the last two lines of the `deflayout` align the part named `pulldown` (of type `rectangular-fet`) so that the top center of the part aligns with the bottom center of the diffusion connection of the part `pullup`. We have specified the alignment of the pulldown

part such that no matter where the pullup part is placed or how large it becomes, the pulldown part will always align with it to form a correct inverter.

One long-term goal of our project is to foster the creation of a large library of highly configurable ICPL cells which will in effect be a collection of module generation procedures that work together. Several advanced users of ICPL have written module generators for many of the regular structures of VLSI design, including random access memories, read-only memories, and programmable logic arrays. In advanced ICPL code, even a simple cell such as an inverter is created by a detailed procedure which creates

(continued on page 9)

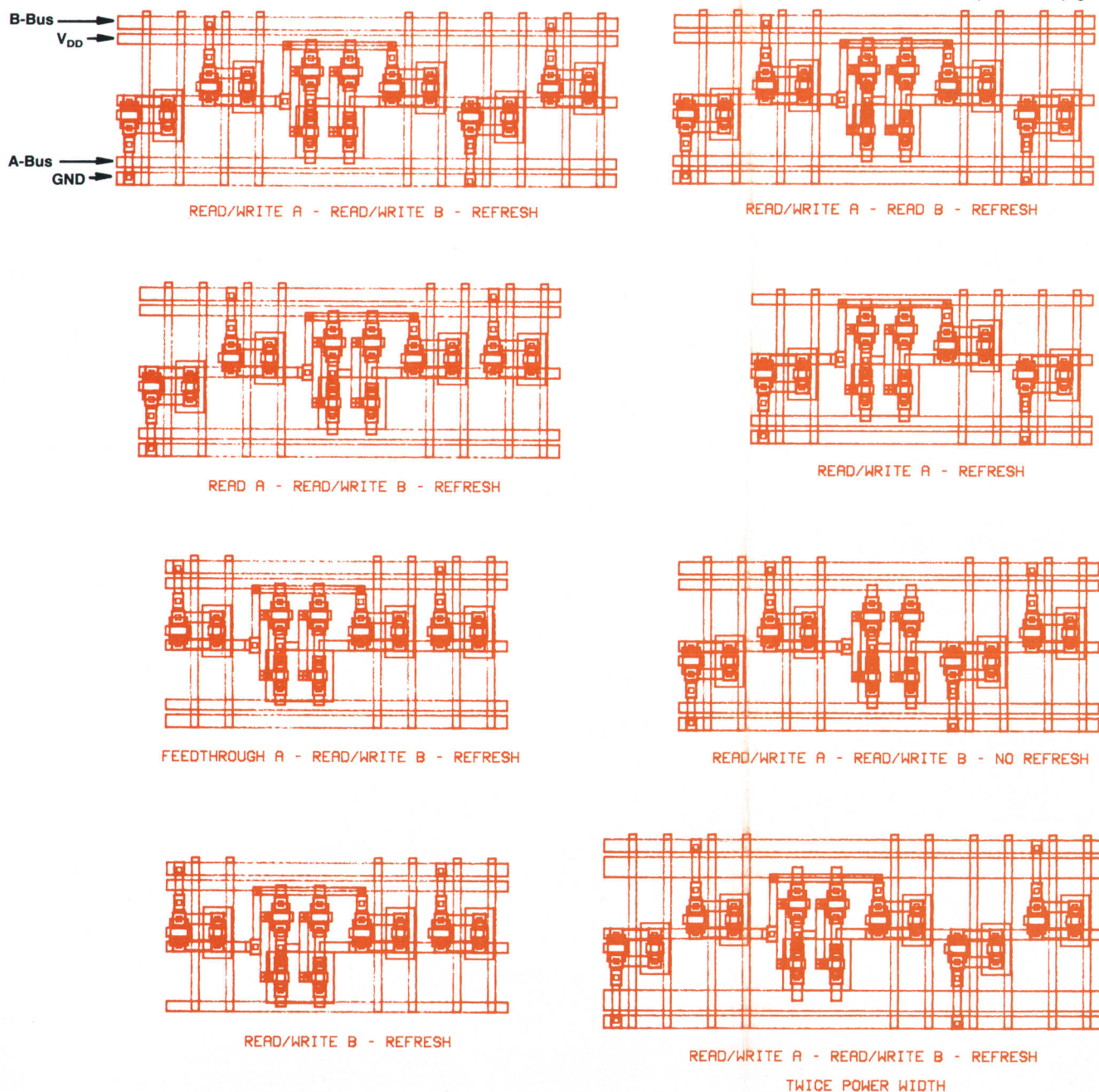

Fig. 3. Configurable CMOS register cell. Some of the fifty possible configurations with two buses are shown.

## Knowledge-Assisted Design and the Area Estimation Assistant

VLSI complexity has increased to the point that it is not unusual to spend several engineer years doing a state-of-the-art IC chip. Software development has faced similar problems. The software engineering problem was handled by raising the level of abstraction at which the programmer operates. Aspects of the solution are the use of higher-level languages for software developers and new programming methodologies and tools to handle the organizational complexity of large programming projects. VLSI design complexity requires a similar solution. One preliminary step is the use of module generators, which allow the designer to build large IC parts such as random access memories without needing to pay attention to the detailed artwork implementation.

### Knowledge-Assisted Design Framework

At HP's Cupertino Integrated Circuits Division, efforts are under way towards the realization of a knowledge-assisted design (KAD) system. We use the term knowledge-assisted to represent the synergy of traditional CAD tools, algorithmic knowledge, and artificial-intelligence (AI) software technology. Primary motivations for such a system include:

- Supplementing, not replacing, the designer. Not all designers who wish to take advantage of VLSI capabilities can do so using traditional CAD tools and methodologies. This is because of the vast amounts of knowledge needed to use these tools to perform VLSI design. In addition to the VLSI-specific knowledge, the amount of knowledge needed just to apply the right tool to the right problem is considerable. An environment that eases the use of new tools for the designer would be quite useful.
- Forming the communication medium in which all parties involved can share and retain information and constraints. The VLSI design process often requires coordination and communication among several different people. The system designer communicates specifications to the IC designer, who in turn communicates with other IC designers, production engineers, and mask designers to achieve chip layout and packaging. Information lost in the transition between designers can result in increased design difficulties. Current design systems are lacking in the ability to capture much of this information.
- Preventing the loss of expertise. A frequent occurrence is the departure or promotion of designers. The experience of those designers is normally lost or becomes very inaccessible to the designers that follow.
- Incorporating expertise from multiple experts. Designers often have to consult with many other designers to achieve the best possible results. However, the required expertise is frequently not available when needed. As an alternative, the KAD system could collect the knowledge of many expert sources, allowing the designer to use the system as a readily accessible group of consultants in the design and critique of the chip.

In one scenario, the designer presents to the system a block diagram for a data path showing interconnections between registers, adders, and multipliers. Certain information may be missing or incompletely specified. The system, in such cases, can assist by filling in much of the omitted information. For example, the chain length for an adder can be deduced from the number of inputs and outputs. This, in turn, provides the means to estimate the maximum time delay, the approximate area that the adder will take up, and the power it will consume. The environment should know what CAD tools are applicable for each design

problem, perform data translation, and interpret results of running simulation and analysis tools.

We intend to provide a KAD framework for tool writers to build knowledge-based tools upon and to provide an intelligent control mechanism for incorporating those tools. We have chosen, as a pilot project, a subpart in this scheme to use as a learning vehicle for understanding what is needed in the framework. Furthermore, this work will bring out in more detail the issues involved in building expert systems within such a framework.

The pilot project is a knowledge-assisted tool for aiding the planning phase of chip design. Such a tool tracks design decisions, attempts to fill in missing details, propagates hints and constraints, and allows the user to explore functional and structural chip design alternatives. In the decomposition phase of chip design, the choice of different design alternatives results in differing impacts upon block and chip area, power consumption, timing delay, and testability. Our initial pilot project will provide feedback on one of these figures of merit—block and chip area estimation for the design.

Thus, there are two parts in this tool. A front-end planning assistant facilitates exploring of design alternatives and a back-end area estimation expert provides analysis information for decision making.

### Planning Assistant

The front-end segment deals with representation and management of functional and structural hierarchies. The problem involved here is to record, distinguish, relate, and apply knowledge of blocks to each new task. During a session, the planning assistant accumulates design vocabularies in terms of block names, part types, and part properties in an attempt to identify design intent and apply its knowledge towards the goal. It allows a designer to build design hierarchy in the designer's own style and terms, using little or no detailed information. When performing a task, it tries to supply the missing detail from facts described by the user, from related works done by some other designers, and from knowledge it has based upon its understanding of similar designs. When these mechanisms fail, the system prompts the user for just enough information to continue the task. The system thus aids in filling in forgotten details and identifying inconsistencies and unnecessary duplication. This should encourage the exploration of as many alternatives as possible to find the best design decision.

The planning assistant can also record useful information such as hints and constraints to be used in later development phases. This creates an on-line notebook capability for the designer and improves information flow between design phases. For example, during the planning stage the system designer may have made a design decision based on the assumption that the RAM module will have an aspect ratio of 1:1. This vital information is stored with the RAM block as the only acceptable aspect ratio. When the design is transferred to the IC designer to implement the physical layout, this constraint is also communicated to the IC designer. The planning assistant can carry large amounts of such information, previously informally passed on only by rough sketches and verbal communication.

### Area Estimation Expert

The back-end area estimation expert provides feedback that can be used recursively in design decision making. We chose



area estimation over several other candidate applications because it is a hard physical constraint for which people usually rely on the most experienced designers to provide answers. We also believe that area estimation should be incorporated into the early design planning phases because, if not done right, it causes expensive global changes in floor planning and is very time-consuming to fix after detailed layout has been done.

Block area can be estimated using information from a few different knowledge sources. First, there are hardcoded numbers for information that has not yet been formalized into any other categories. Next, there are block sizes derived from block boundaries of actual cell libraries the system has access to. Third, there are routines that describe area characteristics for highly flexible parameterized cells such as module generators. These functions take the same set of parameters, but instead of generating the entire physical layout, they only return a value for the estimated area and aspect ratio for the block. Fourth, there is the option, if similar designs exist, of using those designs as a basis for information, provided the relevant differences between designs are accounted for. For example, one can estimate the area for a given block by using area information that exists for a similar block in a different process technology if the two technologies can be mapped from one to another by a numerical transform. Finally, when these mechanisms fail to return a result, the system has two further options. If the block can be further decomposed into simpler blocks, the system will do so and attempt to apply the area estimation mechanisms on the component blocks recursively. If the block cannot be further decomposed (i.e., it is a leaf cell), then the system will either calculate the area based upon gate count or prompt the user for a value.

To acquire the knowledge for this system, we have incorporated in the project team the skills of an IC design expert with whom we have conducted a long series of interviews. Eventually, we hope the system will capture his expertise in making use of all the above information sources, partitioning problems, combining cells, adjusting aspect ratios, consulting different but related designs, making trade-offs, and setting up tolerance ranges for block headroom based upon his confidence level at different steps. There are also interesting techniques discovered in those interview sessions that will contribute to the front-end planning assistant as well, particularly in the way this designer makes use of uncertainties at each phase and handles the iterative design flow of making block definition, decomposition, and recomposition.

Area estimation is more than just adding up numbers. There are assumptions upon which the estimation is made. Availability of library cells and module generators, orientation, aspect ratio, and relative placement of blocks, and intended signal paths are just a few examples of these assumptions. These planning decisions dictate restrictions the subsequent chip recomposition must follow and provide useful technical hints and tricks to help develop layout details.

*Benjamin Y.M. Pan*

*Michael How*

Development Engineers

*Allan J. Kuchinsky*

Project Manager

Cupertino Integrated Circuits Division

the layout based upon specified parameters that account for connectivity requirements, power bus sizing, output load, and aspect ratio.

Several features have been added to ICPL to aid the creation of just such a large procedural cell library. An integrated avoidance capability allows wires to be routed and parts to be placed without regard to specific design rules. Connectivity information is maintained in the same data structures as the layout. This allows detection of such design errors as shorting two global nets together, and neglecting to wire a particular cell. Integrated connectivity means that parts have net attributes just like size and location attributes, and it means that all of the parts tied to a net can be easily found for capacitance extraction or design verification.

A graphical editing capability is also tightly integrated into the ICPL design environment. Developing designs can be viewed on a color display, with mouse-actuated access to the ICPL data structures. Using the mouse, designers have the ability to trace electrical networks, move parts around on an experimental basis, and obtain descriptions of the design hierarchy (see Fig. 2). Layouts entered graphically can also be converted to ICPL code. Although graphical entry is a powerful tool for experimenting with circuit layouts, it is not recommended for the final library cell because it does not capture the intent of the designer. Some users find it helpful to begin a layout graphically and then modify the ICPL code to include the placement constraints that represent their intent.

Geometric structures and their combinations are represented in ICPL as Lisp objects. Arbitrary properties can

be associated with a part, thus enabling Lisp programs such as circuit extractors and cell compilers to store their data on the parts themselves. Through properties, users can extend ICPL to support virtually any configuration they choose. For example, resistance and capacitance values can be determined and tacked onto parts for use with a user-developed circuit simulator. Furthermore, all ICPL data structures are based in Lisp, thus enabling the ICPL programmer to use the full power of the Lisp programming environment.

ICPL is tightly integrated with HP's internal design systems, permitting efficient interchange between ICPL and various circuit simulators, graphical editors, and design rule checking programs. Designers who use ICPL properly can be assured that their designs will weather many process and methodology changes before they become obsolete.

### **Applications of ICPL**

Several complex module generators have been developed using ICPL. A module generator automatically creates the layout for a large piece of a chip, such as the RAM or ROM section. Simpler library cells have also been designed that allow a large combination of parameters to have a large effect on the configuration of the cell. Only one generic cell needs to be designed and stored in the cell library as a template from which many different configurable cells can be produced.

This feature can be shown in the example of the configurable register cell (Fig. 3). This register cell can read from, write to, not connect to, or both read from and write to either of two buses. There is an optional refresh capability,

and the width of the power buses can be adjusted for different current densities and spacing constraints. Fifty different configurations of the register can be generated by passing in different sets of parameters in the part call to the register. This register cell shows that parameterization in ICPL allows a cell library to be more space efficient and provides designers with greater flexibility in selecting the precise cell configurations they want.

An example of a much larger ICPL module generator is the Ramgen project at HP's Cupertino Integrated Circuits Division. Ramgen is a program that captures, optimizes, and generates a general-purpose static RAM (see cover). The modules generated are designed to be equivalent to off-the-shelf RAMs that can be easily inserted into a standard-cell or custom chip. Organization and size of the RAM are user-programmable by specifying the total RAM size desired, the word size, and the aspect ratio. This will create a RAM that will fit not only a variety of functional requirements but also a variety of physical ones. These features allow a chip designer to design a RAM at a high level with the fast design-and-verify turnaround time of approximately ten CPU minutes on an HP 9000 Model 236 Computer (instead of five months handcrafting time) for a 256-bit to 16K-bit RAM. Beyond the time improvement, the user is also guaranteed a working RAM. Ramgen has been used for over a year in the design of nine chips.

One of the most comprehensive module generators under development at HP is the Datapath generator. Datapath enables a complete data path system to be generated from a functional description. Input to the Datapath module generator is a MADL (Multilevel Architecture Description Language)<sup>3</sup> behavioral description of the circuit and the output is the geometric layout of the design in ICPL. Datapath users are provided with two libraries: the MADL library, which contains the behavioral descriptions for simulation, and the ICPL library for artwork generation. A designer only needs to specify the behavioral description for the design and the order in which the library cells should be placed to generate the full data path. The physical layout of each cell is such that cells only need to be placed adjacent to one another for all bus connections to be made automatically. The cells can also be sized for different output drive capabilities by passing in the value of the capacitive load on the driven net. Since ICPL represents net-based connectivity, the calculation of total capacitance of the net is easily done by traversing the net and summing the capacitance of each cell. The design generated by Datapath is readily testable since all the library cells have scan path capability, allowing all the nodes in the design to be excited and observed easily.

## Advanced Work

ICPL has been extended in many ways to take advantage of the powerful environment available in the HP 9000 Series 300 Computer family. Extensive use has been made of the windowing system and the Starbase Graphics Library, and ICPL has been rewritten in Common Lisp to conform to that emerging standard. In addition, expert system tools for layout assistance and silicon compilation are being integrated with the ICPL data structures (see box on page 8). Although still in their infancy, expert systems for CAD have begun to show their worth in solving problems that were intractable using conventional programming styles.

ICPL will provide the basis for powerful silicon compilation tools in the future. The productive Lisp environment, the symbolic nature of ICPL, and integration with expert systems will allow designers to design chips much more rapidly than ever before. It is conceivable that an ICPL-based silicon compiler could take an initial chip specification, generate artwork, and continually iterate through the design, refining the weakest areas (in size, speed, power consumption, etc.) until the design converges on the optimum. Users will be able to get the power of VLSI design without needing to be familiar with the fine details of IC design techniques.

## Acknowledgments

The authors would like to thank and acknowledge a number of people for their contributions to ICPL. These include William Barrett, Bob Rogers, and Mike Sorens for their early work in the design and implementation of ICPL, Bill McCalla, Joe Beyers, Marco Negrete, and the late Merrill Brooksby for their support, Ira Goldstein, Martin Griss, Craig Zарmer, Chris Perdue, Alan Snyder, and Gwyn Osnos for their help with the Prism system (and with our early questions), and certainly Liz Myers, Dave Wells, Jon Gibson, Ed Weber, Pete Fricke, Shaw Yang, Duksoon Kay, and Rick Brown, who have beautifully demonstrated the feasibility of using Lisp-based design tools in building production chips.

## References

1. J. Batali and A. Hartheimer, "The Design Procedure Language Manual," *AI Memo #598, VLSI Memo 80-31*, Massachusetts Institute of Technology, Artificial Intelligence Laboratory, September 1980.
2. B. Infante, M. Bales, and E. Lock, "MADL: A Language for Describing Mixed Behavior and Structure," *Proceedings of the IFIP Sixth International Symposium on Computer Hardware Description Languages and their Applications*, May 1983.

# New Methods for Software Development: System for Just-in-Time Manufacturing

*New approaches in prototyping, next-bench involvement, performance modeling, and project management created a high-quality software product in the absence of standards or existing systems.*

by Raj K. Bhargava, Teri L. Lombardi, Alvina Y. Nishimoto, and Robert A. Passell

**H**P JIT IS A SOFTWARE SYSTEM that assists in the planning and control of material and production for manufacturing facilities operating with a new manufacturing technique developed in Japan and known as just-in-time. Just-in-time manufacturing reduces complexity on the factory floor by using fixed production routings and a pull system for material handling. In a pull system, raw materials are delivered to the factory floor as they are consumed in production. This simplifies manufacturing management.

## About HP JIT

HP JIT is designed to be a stand-alone product or to run in a combined environment with HP Materials Management/3000.<sup>1</sup> The combined system allows a user to avoid redundant parts and stock area data when both the traditional work-order material requirements planning and just-in-time philosophies are used in the same facility.

The majority of the HP JIT software runs on the HP 3000 Computer, using Hewlett-Packard's Application Customizer<sup>2</sup> and Monitor<sup>3</sup> technology. The Application Customizer and Application Monitor are themselves software tools that are used by application designers to engineer generalized software systems, and then by users to adapt the systems to their individual needs. HP JIT also uses the HP 150 Personal Computer as a management workstation. The HP 150 Computer can serve as the interface to the HP 3000 Computer for accessing the material and production functions, or as a stand-alone personal computer for access to local decision support tools.

HP JIT is meant to complement the characteristics of a just-in-time method of production, including:

- Fixed production routings on the factory floor
- Single-level bills of material (flat structure)
- Planning by production rate to accommodate steady production targets over a period of time
- Short production cycles featuring quick assembly.

HP JIT has seven major software modules (see Fig. 1), each of which addresses a different requirement of the just-in-time manufacturing method:

- Parts and Bills of Material
- Rate-Based Master Production Scheduling
- JIT Material Requirements Planning
- Production Reporting and Post-Deduct
- Stock Areas and Deduct Lists

- Inventory Management
- Material Cost Reporting.

*Parts and Bills of Material* maintains basic information on every part used in production, recording product structure, standard costs, and data on product options and engineering changes. Its features include single-level manufacturing bills of material, effectivity dates for engineering changes, pseudoparent parts to represent subassemblies consumed in production, multiple product options, and ABC part classification.

*Rate-Based Master Production Scheduling* matches proposed production and shipment schedules against backlog and forecast orders to manage finished goods inventory more effectively. Planning is accomplished without work orders, with monthly production of each end product based upon a planned rate of output for that product per day. Schedules for different production lines producing the same product can be adjusted separately. The features of this module include a predefined VisiCalc<sup>®</sup> spreadsheet, "what-if" capability for production planning, graphics for reporting of monthly plans, automatic data transfer between the HP 150 Personal Computer and the HP 3000 Computer, an interface for forecast and backlog information, and a five-year planning horizon. Fig. 2 shows a master production schedule produced using HP JIT.

*JIT Material Requirements Planning* determines the

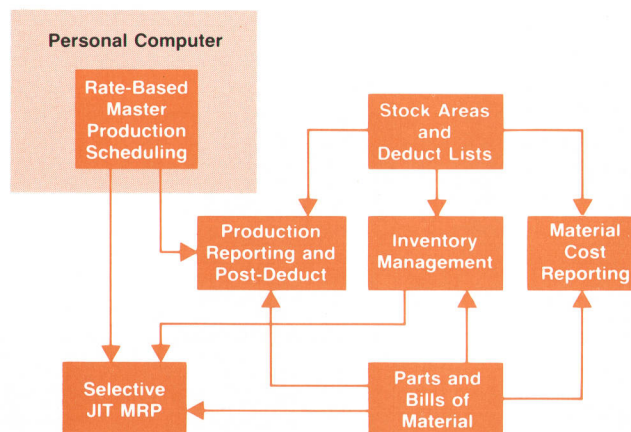

Fig. 1. Seven major software modules make up the HP JIT package for just-in-time manufacturing.

quantities of parts required to support the master production schedule, daily production schedule, and planned extra use of component parts. JIT MRP reports can be run selectively over a range of part numbers, controllers, buyers, or dates, or according to selection criteria of the user's choice in either daily, weekly, or monthly increments, or some combination of these. The features of this module include selective MRP by date range, component part range, controller/buyer range, or other user-defined attribute, single-level explosion, option mix planning, option effectivity dates, and action/preshortage reports. Fig. 3 on page 14 shows a JIT MRP screen for entering select criteria for an MRP run.

**Manufacturing Control**

Manufacturing control is carried out on the factory floor via the post-deduct transaction and the *Production Reporting and Post-Deduct* module, which records actual production completed and, at the same time, relieves stock areas of inventory consumed in assembly. Post-deduct is a one-step approach, as opposed to the traditional "issue and receive" of a work-order-driven production reporting system. Defining a deduct point in HP JIT provides visibility of the consumption and movement of materials on the factory floor. As a part is built and passes through a defined deduct point, HP JIT records the creation of the part, incrementing its inventory quantity and decrementing the inventory quantities for its components. On-line review of actual versus planned production is provided in HP JIT. The features of the *Production Reporting and Post-Deduct* module include post-deduct of up to 25 options per parent at a time, post-deduct by engineering change level, post-deduct at subassembly or end-product levels, summarization capability that allows tuning of the HP JIT system by the user to optimize performance, and actual production reporting by the hour or by the day. Reviews of planned versus actual production use graphics. Fig. 4 on page 15 illustrates an HP JIT post-deduct transaction.

The *Stock Areas and Deduct Lists* module further defines the manufacturing process. Corresponding to each deduct

point is a deduct list which associates the component parts and their quantities consumed at that deduct point with the stock areas from which those components were picked in the assembly process. The features of this module include multiple stock areas per part, multiple deduct-point types (intermediate, end-of-line, subcontract), multiple deduct points per line, multiple production lines per product, and split, merged, and mixed-mode production lines.

*Inventory Management* maintains the current status of each stock area and updates its status through the post-deduct, scrap, or extra use transactions. The features of this module include on-line inventory balances, multiple stock area status codes (available, unavailable, scrap, inspection), recording of scrap and extra use, two-stage cycle counting, and inventory count and adjust capabilities.

*Material Cost Reporting* summarizes accounting information on materials produced during an accounting period. This module features production data summarized by individual product, exception data recorded on an individual transaction basis for visibility, and material variances calculated based on scrap and extra use recorded.

**Development Cycle**

The HP JIT development project was significantly different from software development projects that preceded it. New methods for engineering this type of software were introduced to meet the objective of producing a high-quality product in a shorter period of time than had been typical.

Fig. 5 on page 16 shows two time lines contrasting the traditional and HP JIT development cycles. The remaining sections of this article detail some of the methods used in the HP JIT project to change the typical project cycle.

**Prototypes**

The HP JIT project provided an opportunity to try a different approach in the investigation and external specification phases of a large software project.

The traditional method produced investigation and external specification documents for review, but these documents were generally felt to be an ineffective method of

Hewlett Packard - \*\*\*YOUR COMPANY NAME \*\*\*  
Master Production Schedule

Product Number. . . . .	93827A			
Month . . . . .	12/85	01/86	02/86	03/86
Number of working days. . . . .	21	23	19	23
Past Due Production . . . . .	10			
Production Rate/Day (prev plan) . . . . .	0	0	0	80
(curr plan) . . . . .	15	10	10	80
Backlog Orders. . . . .	200	180	130	100
Order Forecast. . . . .	50	50	90	130
Carry Forward Orders. . . . .	0	0	0	0
TOTAL Orders. . . . .	250	230	220	230
Production/month. . . . .	325	230	190	1840
Beginning FGI . . . . .	0	75	75	45
TOTAL Shippable Units . . . . .	325	305	265	1885

Fig. 2. An HP JIT master production schedule.

## Comparing Manufacturing Methods

The difference between the batch stock flow of a traditional manufacturing system and the demand-pull stock flow of a just-in-time system is illustrated by the following example.

Fig. 1 shows that product A is composed of two parts, B and C. Part C is purchased, while part B is fabricated from purchased parts X and Y.

Fig. 2 shows traditional batch stock flow. Parts X, Y, and C are received, inspected, and placed in the warehouse. An X and a Y are released to a work order WO1, which uses these parts to

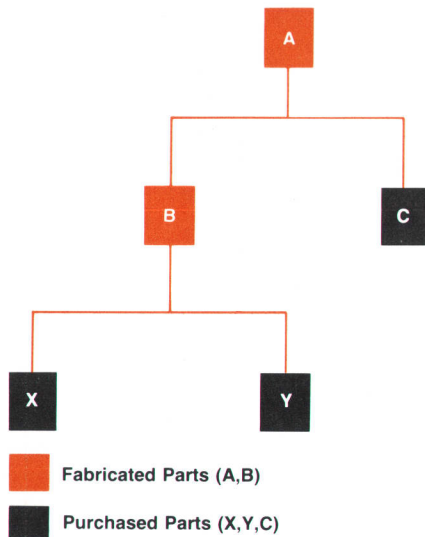

Fig. 1. Assembly sequence for a product A.

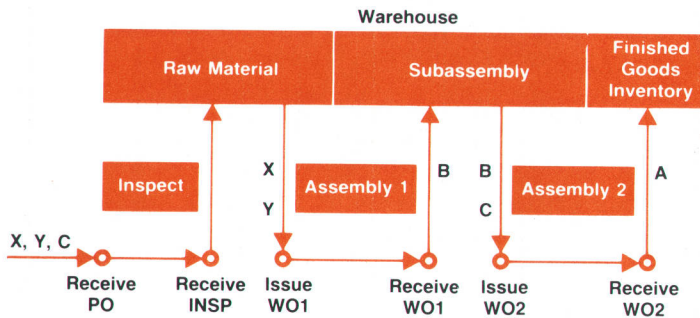

Fig. 2. Traditional batch stock flow.

communication. Many readers found it difficult to visualize the final product solely on the basis of written specifications, and often did not review the documents carefully.

External specification documents typically spend a great deal of time in the draft stage, going through a lengthy draft-review-rewrite cycle before they can be shown to end users, field marketing, and others outside of the development team in the lab. The time spent drafting the external specifications is a period when much of the progress on the project is not readily measurable. This makes the process of creating the product difficult to manage during this stage, and in the worst case, makes it possible for the project team to lose their focus.

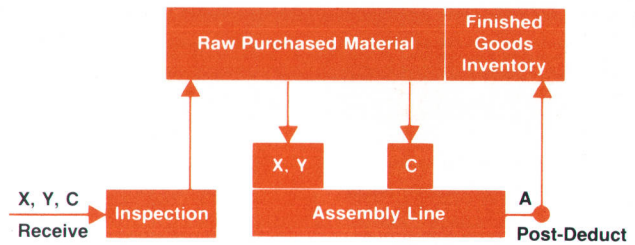

Fig. 3. Demand-pull stock flow. Just-in-time manufacturing may also eliminate incoming inspection so that parts flow directly from receiving to production.

create subassembly B, which is returned to inventory. Subassembly B and part C are then released to work order WO2, which uses these parts to create the finished product A, which is placed in finished goods inventory.

Fig. 3 shows demand-pull stock flow. Parts X, Y, and C are received, inspected, and delivered to their stock locations. An X and a Y are used in the creation of subassembly B, which then travels down the production line to the point where part C is added, resulting in the creation of product A. Raw material and finished goods inventory adjustments are made at this time by means of the post-deduct transaction.

Besides eliminating the work orders and subassembly storage of traditional batch stock flow, demand-pull stock flow makes it possible to introduce further improvements that are now considered characteristic of the just-in-time manufacturing method. These are the elimination of incoming inspection and the flow of parts directly from receiving to production.

With these concerns in mind, we decided to try a different approach on the HP JIT project. Rather than use the traditional method of creating an external specification document, we decided that software prototyping was a much better channel for feedback and would allow us to solicit customer and marketing input early in the development cycle, when it would be most effective in determining the feature set of the product and providing a basis for the internal design. Prototyping the software at this point in the project provides the best basis for asking vital questions about the proposed feature set of the product, and for seeking answers to these questions iteratively, by means of successive prototypes that incorporate customer feedback.

Prototyping also helped reduce the risk in the early stages

of product engineering by unifying the development team's own understanding of the product, making the features and functionality of the system more tangible. This helped identify potential problems in system design early and minimized costly engineering redesign in the later phases of the project.

Our strategy for implementing prototypes was to produce a prototype in three to four weeks. We felt prototypes should be done quickly, using whatever tools were available. Their purpose was to allow us to iterate the solutions to vital questions.

The prototypes were not meant to be an early stage of the coding phase, since the prototypes were to be thrown away after the features or problems they addressed were understood. No attempt was ever made to use any actual prototype implementation later, since we felt that this would inhibit the project team from solving the problems quickly. If an actual prototype were to be used later as the basis for some effort in the coding stage of the project, we felt that we would quickly become overly concerned with engineering the "perfect" prototype during the investigation and lose our focus on asking vital questions and solving problems that the prototypes were supposed to address.

In the JIT project, there were six simulators and prototypes as follows:

- Screen simulator I (3 weeks). Test high-level product definition.
- HP 150 prototype of HP 3000 link (4 weeks). Test technology of HP 150 link.
- HP JIT functional prototype (3 weeks). Test design of data base and critical transactions (performance).
- Screen simulator II (3 weeks). Test functional design.
- Screen simulator III (3 weeks). Test user interface.
- Screen simulator IV (3 weeks). Refinement.

At the end of this process a concise document was written to confirm the consensus of the customer, marketing, and lab input we had received on the prototype models of the

product. Instead of the traditional approach, where a document is produced for review and revision before the product feature set is determined, the document produced for our project was effectively a summary of what the project team had agreed upon, based on the results of an iterative prototyping process.

To summarize, in the traditional method, documents were an ineffective method of communication. People often did not review documents carefully. It is difficult to visualize a software system solely through the use of a document. There could be long periods of time during the drafting of the document when no progress on the project was visible. A lengthy review was required to get agreement on product specifications, and there was little involvement outside of the development lab before the document review cycle was completed. This brought considerable risk to the process of developing the product and made it difficult to measure whether the project was on track or not.

In contrast, the HP JIT project used prototypes to provide a tangible display of product functions and features during the design phase of the project. This proved to be an extremely effective method for communication and elicited more thorough feedback from potential users, who could visualize the final product more fully based on the initial prototypes. The many iterations of the product prototypes, each one progressively refining the feature set of the product, provided the product with an opportunity to establish many short milestones and made progress during the development phase more visible and measurable. The involvement of end users and marketing during the early phase of product design decreased the risk of redesign and reengineering later on in the project.

**Next-Bench Involvement**

HP is widely recognized as an industry leader in implementing the just-in-time production method. A primary objective of the HP JIT project was to work closely with

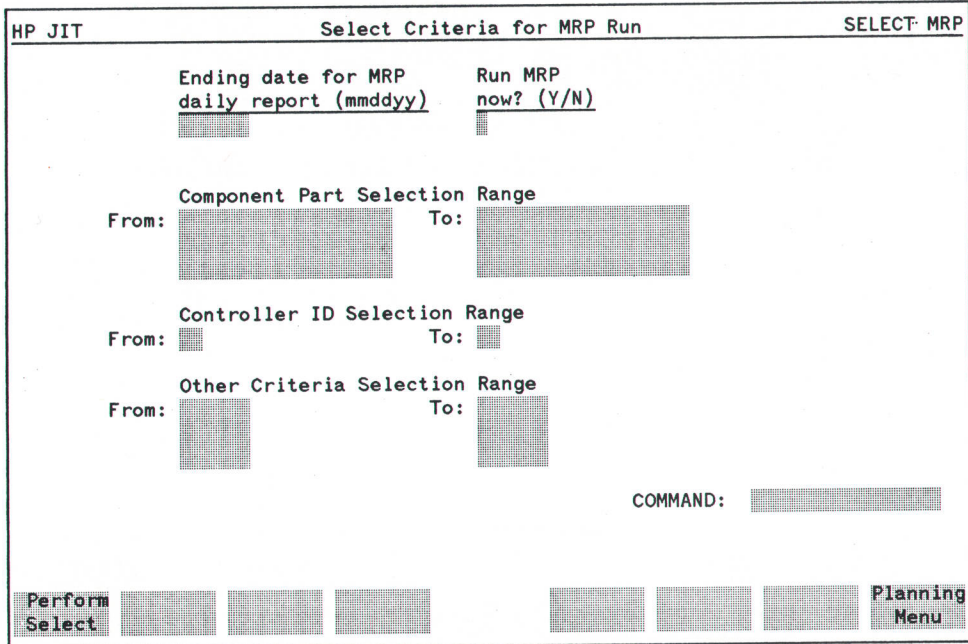

Fig. 3. An HP JIT screen for entering select criteria for an MRP (material requirements planning) run.

HP divisions that practice JIT so that we could quickly develop a product that would suit HP's internal needs as well as those of the marketplace.

To meet both internal and external needs, several important requirements must be satisfied. There must be both management commitment and individual commitment throughout the project teams at divisional sites participating in the development process. More than one external division must be involved, and each must dedicate someone full-time to the project. In practice, the partner division teams communicated among themselves so effectively that many disagreements about product requirements were resolved without intervention by the development team in the software lab.

The partner divisions played an important role in all phases of the project. During the design phase, increased productivity in the software development lab resulted from their review of the prototypes and specifications, eliminating a significant amount of guesswork on the part of the design engineers when adding new product features. The partner divisions helped eliminate guesswork during the final coding phase by testing product quality and verifying that the software indeed solved the problems it was designed to handle and correctly provided the features specified. The credibility of HP JIT as a product was increased by the combination of HP's being looked upon as a just-in-time manufacturing leader in the U.S.A. and the partner divisions' acting as reference sites showcasing HP JIT.

#### Application Architecture

HP JIT was designed to be coded in Pascal and to use the CT (customizable technology) software tools developed by HP's Administrative Productivity Operation.<sup>4</sup> CT software tools free the application designers from much of the detail work involved in opening data bases and files, handling terminals, and updating screens. HP JIT went farther,

however, and placed many of the common calls to the underlying CT tools inside of utility subroutines in the product that could be called from any of its modules (see Fig. 6). Utilities were written for data base searches, screen handling, and transaction logging, as well as other more specific JIT functions. The initial impetus behind the development of these utilities was to avoid duplication of Pascal source code, but each utility was designed for maximum flexibility so as to be usable by transactions and modules yet to be developed. Through the use of flexible common utilities, duplication of Pascal source code throughout the HP JIT software was nearly eliminated.

Building an application such as HP JIT on top of a layer of utility procedures has many significant advantages. Eliminating code duplication not only reduces overall code length, but also reduces source code clutter in individual modules, thereby helping to preserve transaction clarity. Relying on many shared utility procedures eliminates the risk of errors caused by oversight and accident when replicating source code throughout many individual modules. Code maintenance and product enhancement are made simpler, since a correction or enhancement can often be made in a utility module and effected immediately throughout the entire application by replacement of the utility module alone. Some utilities (e.g., screen handling and data base operations) can be used by similar software systems, saving time and effort when developing and testing other products. Reliability is increased, since a utility called by several different individual transactions is exercised thoroughly during testing.

Some typical HP JIT utilities are:

compare_lines	On a screen with multiple data entry lines, determine that the user hasn't entered any duplicates.
dataset_msg	Inform the user about the success or failure of finding or not finding a requested data item.

HP JIT	Post Deduct a Parent Part	POST DEDUCT
<u>Parent Part Number</u>	<u>Option ID</u>	
<u>Deduct Point ID</u>	<u>Quantity Deducted</u> <u>UM</u>	<u>Description</u>
<u>EC Level</u>	<u>EC Level Used</u>	<u>Change Default EC Level? (Y/N)</u> <u>EU Type</u>
		<u>COMMAND:</u>
<u>Perform Deduct</u>	<u>Pull Part</u>	<u>Receive Part</u> <u>Scrap Component</u> <u>EU Component</u> <u>Mfg Cntl Menu</u>

Fig. 4. The HP JIT post-deduct transaction records production completed and simultaneously relieves stock areas of inventory consumed in assembly.

find_datasetrec,	Locate an entry or entries that match a set of criteria parameters in the specified data base.
multi_find_dataset	
process_maint	Do all screen handling for the HP JIT maintenance transactions.
valid_in_security	Check user access to screen.
valid_input	Determine that key input fields on screen are valid for the transaction.
open_message_file	Open a specified MPE message file. Create it if it doesn't exist.
lock_datasets	Lock the specified data items or sets as specified by key parameters.
input_required	Verify that a list of fields has been input.

### Performance Modeling

In the HP JIT project, we decided to try a new approach to the performance testing of our application projects. The old method collected a lot of data with little idea of the questions being answered. In addition, performance tests tended to be done after the product was coded. Any bad news was received too late, when it was costly to redesign and recode.

The HP JIT project established performance objectives in customer terms before any coding or design had been done. After we first modeled performance, we continued to refine the model based on actual performance test results.

Our performance model uncovered a major performance problem with our most critical transaction, post-deduct, before we completed designing or began coding the product. One post-deduct transaction can result in up to 400 separate data base updates. According to the model, the maximum production rate, or the rate that HP JIT can handle with real-time updates of component part consumption, is given by:

$$\text{Maximum Production Rate} = \frac{3600 - 0.75P}{0.25 + 1.5D/L + E/L}$$

where D is the total number of deduct points, P is the total number of parents, L is the number of production lines, and E is the total number of deduct list elements.

This model showed that for a low-volume customer, even the best case would cause this transaction to take 2.7 hours to process one hour of customer data. This meant that even for a low-volume customer, the post-deduct transaction would never catch up with incoming data that it was intended to process.

To solve this problem, we designed this transaction to summarize the processing of the data, allowing the customer to specify the summarization interval. The model allowed us to provide a formula to help customers decide what summarization interval would fit their type of data and rate of production. The formula is:

$$\text{Summarization Interval} = \frac{1.25DP/L + 0.75P + E + 900R}{1 - 0.5DR/L}$$

where D, P, L, and E are as above and R is the total production rate per second.

### Quality Procedures

Quality was built into HP JIT using a variety of techniques. In the lab, formal design reviews and code inspections were used throughout the development process, and this contributed to improving the overall functionality and correctness of the code for each module. The use of utility routines to perform shared functions for separate application modules contributed to quality by eliminating manual duplication of code. Since these utilities are accessed by a variety of calling routines, any defects or deficiencies were detected early, and the utilities eventually proved to be very robust. HP JIT also made use of its partner divisions within HP as alpha and beta test sites during the design and development phase of the product. These partners were actively implementing just-in-time manufacturing tech-

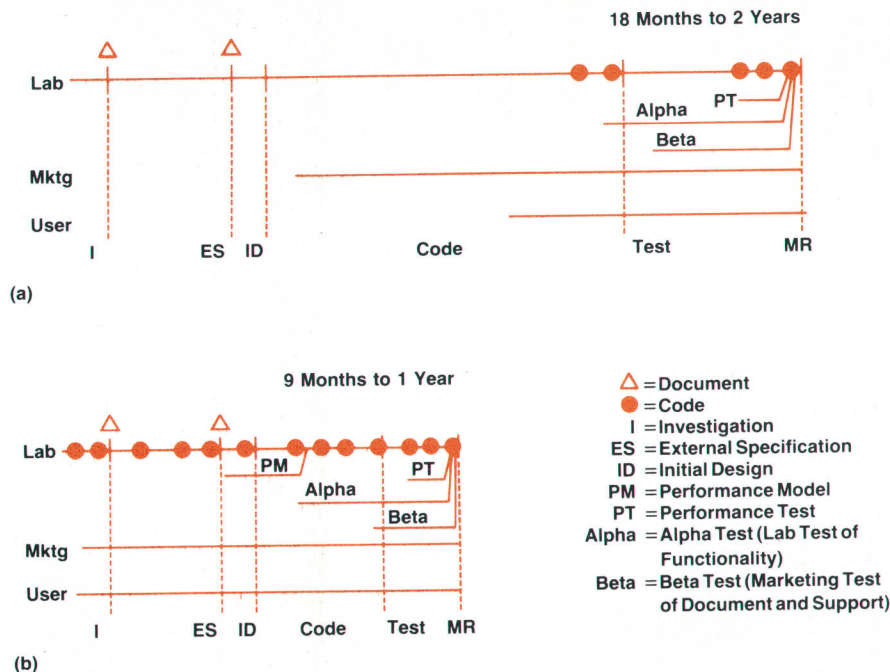

Fig. 5. (a) Traditional software development cycle. (b) The HP JIT development cycle was shorter than the traditional cycle. Software prototyping replaced the usual investigation and external specification phases.



niques and thus were qualified to assist in the design of the product and test its functionality. Each partner was allowed to narrow its focus to a particular testing objective. This made the process of testing more manageable and the testing more thorough. "Mini-releases" of HP JIT to the partner divisions throughout the design and development stages kept the testing effort progressing actively and kept the partners from feeling overwhelmed by bulky new versions of the product with large doses of new functionality. Each of the partner divisions was assigned a member of the HP JIT lab team for support, providing quick feedback and fostering closer ties throughout the entire development team.

### Project Management

One of the essential ingredients that made HP JIT a success was the innovative project management. We recognized the need to make quick decisions as a team. At times, this meant taking action even when we did not possess complete or adequate information. However, we were willing to take risks and accept the fact that we would learn along the way. We expected that as we gained more experience our decisions would have to change. We did not resist change, but managed it so we could meet our milestones and objectives.

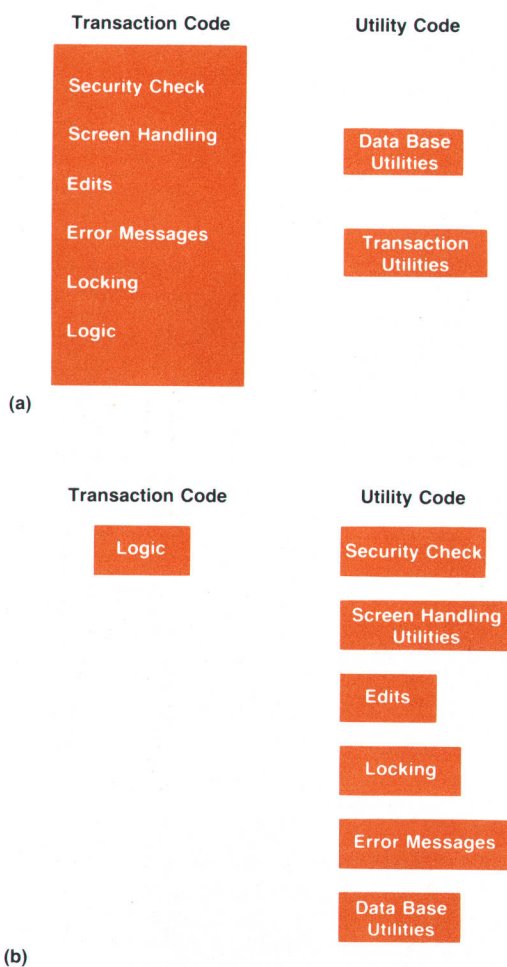

Fig. 6. (a) Traditional software coding. (b) HP JIT coding built the product on a layer of utility procedures.

We planned milestones in 4-to-6-week intervals. These milestones were measurable and very visible to people involved in the project. The lab team then viewed these as "hard" milestones and every effort was made to meet them. With these frequent milestones it became much easier to measure our progress, providing focus and great satisfaction to the team as we met each milestone.

We emphasized leveraging existing resources and avoided duplication of effort. At each step we tried to direct our efforts to activities that could be used in the final product package. For example, the external specifications became the starting point for the user manual. We always went through iterations before making decisions and starting to build. However, once a component of the product had been built or a specification defined, we resisted augmentation and rework. Early in the project all dependencies were defined and contingency plans were developed. We recognized that some dependencies were absolutely essential and no backup was available. However, we made it an objective to minimize dependencies on the critical path.

The three most important overall goals for the HP JIT project were:

- To invent a high-quality software product where there was none before, either internally or externally
- To meet all scheduled milestones, the most important being the MR (manufacturing release) date, which was stated at the beginning of the project
- To increase the productivity of engineers in designing this type of software product.

The design of the product was influenced from its earliest stages by groups that would have a major influence on its ultimate success: JIT practitioners and HP product marketing. The process of designing functionality and quality into the product was enhanced by the use of rapidly developed prototypes as a basis for communication about product function and design. The establishment of frequent milestones, each with a deliverable part of the product (from prototype to completed module) aided in sustaining the momentum of the project team and kept the effort successfully on track from start to finish.

### Acknowledgments

Nancy Federman was the R&D project manager for HP JIT until the first release of the product. We would like to thank her for her leadership and for developing some of the figures used in this article. We would also like to thank product team members Steve Baker, Marc Barman, Jim Heeger, Pamela Hinz, Kristine Johnson, Mike Kosolcharoen, Mary Ann Poulos, and Chris Witzel for their contributions in developing HP JIT. Our thanks also to Computer Systems Division (Cupertino and Roseville), Disc Memory Division (Boise), San Diego Division (San Diego), and Vancouver Division (Vancouver) for their active participation and feedback.

(continued on next page)

## References

1. N. C. Federman and R. M. Steiner, "An Interactive Material Planning and Control System for Manufacturing Companies," *Hewlett-Packard Journal*, Vol. 32, no. 4, April 1981.
2. L. E. Winston, "A Novel Approach to Computer Application System Design and Implementation," *ibid.*

3. B. D. Kurtz, "Automating Application System Operation and Control," *ibid.*
4. J. L. Malin and I. Bunton, "HP Maintenance Management: A New Approach to Software Customer Solutions," *Hewlett-Packard Journal*, Vol. 36, no. 3, March 1985.

# Authors

June 1986

## 4 ICPL

### Allan J. Kuchinsky



With HP since 1978, Allan Kuchinsky manages the Lisp tools group at HP's Cupertino IC Division. His contributions include work on HP Production Management/3000 and on ICPL. He is a coauthor of three technical papers and is a member of the IEEE and the American Association for Artificial Intelligence. Allan was born in Brooklyn, New York and studied psychology at Brooklyn College (BA 1971). He taught science at a New York City secondary school and was a high school biology teacher in Mexico City. He has also worked as a musician. Before coming to HP he completed work for an MS degree in computer science in 1978 at the University of Arizona. Now a resident of San Francisco, he's married and has one son. He enjoys playing his guitar, listening to reggae music, and spending time at music and comedy clubs. He's also fond of reading science fiction and murder mysteries.

### Andrew A. Berlin

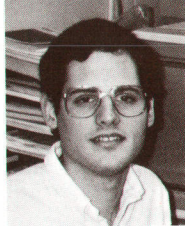

With HP since 1985, Andy Berlin is an R&D engineer at HP's Cupertino IC Division. He has contributed to the development of ICPL and has taught an HP software engineering class. He was born in New York City and holds a 1985 SBEE degree from the Massachusetts Institute of Technology. Andy lives in Cupertino, California, and enjoys playing piano.

### Jeffrey A. Lewis

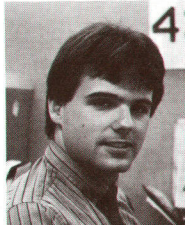

Jeff Lewis was born in Oakland, California and studied economics and computer science at the University of California at Berkeley, completing his studies for both the AB and BS degrees in 1983. While still a student, he worked for IBM as a circuit designer. After coming to HP in 1983 he contributed to the development of an IC design tool and later became the technical leader for the ICPL project. He is a coauthor of one other article on ICPL and is interested in procedural layout and Lisp programming. Jeff and his wife live in Mountain View, California. His outside interests include running, bicycling, scuba diving, and skiing.

### Robert A. Passell

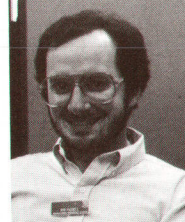

Born in Milwaukee, Wisconsin, Bob Passell attended the University of Wisconsin at Madison, from which he received a BA degree in English in 1975 and an MBA degree in 1978. He was also a budget and management analyst for the University and studied computer science until joining HP in 1981. He was first a programmer/analyst and then a software engineer, and has contributed to the development of HP Maintenance Management/3000 and HP JIT. He's interested in computer-based management information systems for manufacturing environments. A resident of San Jose, California, Bob is married and has two children. He likes spending time with his family, motorcycle touring, fishing, hunting, and cultivating roses.

### Teri L. Lombardi



Teri Lombardi is a 1982 graduate of California Polytechnic State University at San Luis Obispo, from which she received a BS degree in computer science. After coming to HP in 1983 she worked on HP Materials Management/3000 and HP JIT and has since left the company. A California native, she was born in Healdsburg and lives in San Jose. Her hobbies include water skiing, flying and sewing.

## 11 HP JIT

### Paul K. Yip

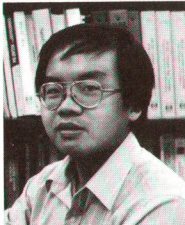

An alumnus of the University of Illinois, Paul Yip has a 1982 BSEE degree and a 1984 MSEE degree. He has been with HP since 1984 and has enhanced and supported an HP multilevel simulator as well as working on ICPL and silicon compilation. He is a coauthor of two articles on the simulation of VLSI design and is interested in design automation, silicon compilation, and expert systems. Paul was born in Canton, China and grew up in Hong Kong. A resident of Sunnyvale, California, he likes jogging, skiing, and basketball.

### Alvina Y. Nishimoto



Alvina Nishimoto was born in Honolulu, Hawaii and specialized in computer utilization at Stanford University. Both her BS and MS degrees in industrial engineering were completed in 1978. With HP since 1978, she is a software engineer and has worked on the development, enhancement, and support of HP Materials Management/3000. She is currently a member of the team that developed HP JIT. Alvina lives in Sunnyvale, California with her husband and enjoys watching and participating in ballet and dance.

### Raj Bhargava

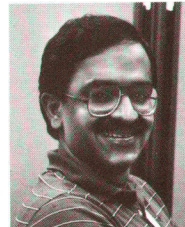

An R&D project manager at HP's Manufacturing Productivity Division, Raj Bhargava has been with the company since 1981. He was born in London and earned a BS degree in mechanical engineering from Banaras Hindu University in 1978. He continued his education at Pennsylvania State University (MSME 1979) and at the University of Michigan (MBA 1981). He also held research assistant positions at both Pennsylvania and Michigan. At HP he has led the initial implementation of the HP Desk

network for the computer divisions, has led a software development team for HP JIT, and has managed the integration of HP JIT and HP Materials Management/3000. He is currently responsible for HP Materials Management/3000 product engineering. Raj lives in Milpitas, California with his wife and daughter. He likes racquetball, tennis, running, and hiking.

## 20 Doppler Cardiac Diagnosis

### Raymond G. O'Connell

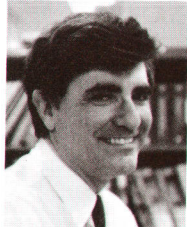

Born in Annapolis, Maryland, Ray O'Connell is a graduate of Worcester Polytechnic Institute (BSEE 1966) and Northeastern University (MBA 1976). He joined HP in 1966 and has contributed to the development of HP medical products, including the HP 7822A Arrhythmia Monitor and the HP 78301A Bright Display. He was project manager for the HP 77400A Display Subsystem and the HP 77410A Doppler Processor and now manages the development of color flow mapping hardware. Ray lives in Andover, Massachusetts, is married, and has four children. His outside interests include sailing and writing computer games.

## 26 Doppler Theory

### Paul A. Magnin

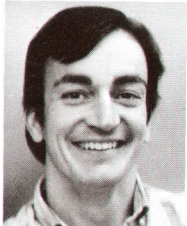

Paul Magnin earned a BSEE degree from Princeton University in 1977 and a PhD degree from Duke University in 1981. With HP since 1981, he is a specialist in Doppler flow mapping and the author of 12 papers on phased array imaging and Doppler effects. He contributed to the development of the HP 77410A Doppler Processor and is currently an R&D project manager. Paul was born in Marion, Indiana, and now lives in Andover, Massachusetts with his wife and son.

## 31 Power/Intensity Measurements

### James Chen



Born in Nanking, China, James Chen earned a BS degree at Chung Yuang University in Taiwan in 1970. He also received a PhD degree in physics from Boston College in 1976 and did research on ultrasound material and nondestructive evaluation related to the nuclear industry before coming to HP in 1981. His primary contribution at HP has been to phased-array transducer development. He is the author or coauthor of several conference papers and his work on acoustic imaging devices is the subject of both a patent and a patent application. James lives in Chelmsford, Massachusetts, is married, and has three children.

## 35 Blood Flow Data Extraction

### Leslie I. Halberg



An R&D engineer at HP's Andover Division, Les Halberg has worked on front-end analog signal processing for the HP 77410A Doppler Processor and on color video signal processing for the HP 77420A Color Flow Subsystem. Before coming to HP

he used high-frequency ultrasound to evaluate materials at General Electric and also developed and evaluated SiGe alloys for semiconductors. He is the author of several technical papers and is named inventor on two patent applications related to ultrasound. Les was born in New York City and received a BS degree in chemical and biomedical engineering from Columbia University in 1977. He earned his MSEE degree from the University of Cincinnati in 1979. Les and his wife and two children live in Malden, Massachusetts and he's a youth group advisor. He plays softball and is a photographer and avid handball player. He's currently landscaping his back yard and says he has plenty of spare rock if anyone is interested.

### Karl E. Thiele

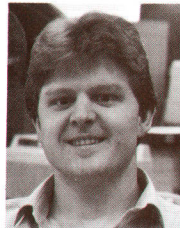

Karl Thiele was born in Los Angeles, California and attended Rensselaer Polytechnic Institute, completing work for his BS degree in biomedical engineering in 1982 and for his MSEE degree in 1983. After coming to HP the same year he helped develop the detector subsystem for the HP 77410A Doppler Processor and is now working on the theoretical aspects of color flow mapping. His other professional experience involved work at IBM on RISC architecture. He is interested in communication theory and analog circuit design. A resident of Stoneham, Massachusetts, Karl enjoys night life in Boston and investing in the stock market. He's involved in many sports, including racquetball, softball, volleyball, weight lifting, and triathlon events.

## 41 Imaging Scanner Modification

### Sydney M. Karp



Born in Queens, New York, Syd Karp is a graduate of Rensselaer Polytechnic Institute (BSEE 1976). With HP since 1979, he has contributed to the design of the transmitter and processor for the HP 77200A Scanner, worked on Doppler software, and participated in clinical trial evaluations and enhancements of the HP 77200A. Before coming to HP he designed radar signal processors. Syd lives in Somerville, Massachusetts and is an avid landscape photographer. He has been a gold medal winner in the Photographic Society of America annual competition. He also plays ice hockey and is a Boston Bruins hockey fan.

## 45 Doppler Digital Processing

### Barry F. Hunt

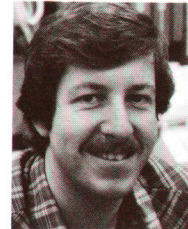

Born in Chicopee, Massachusetts, Barry Hunt has been with HP since 1979. He has contributed to the development of the scan converter for the HP 77400A Display Subsystem, the HP 77410A Doppler Processor, and the HP 77420 Color Flow Map Subsystem. He studied computer systems engineering at the University of Massachusetts, receiving his BS degree in 1977, and worked on digital design for missile-borne computers before coming to HP. He is named coinventor on two patents related to scan conversion and is the coauthor of a past *HP Journal* article. Barry is married and lives in Nashua, New Hampshire. He and his wife are expecting their first child later this year. His hobbies include softball, golf, writing, and personal computers.

### David C. Hempstead

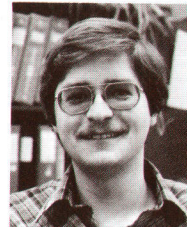

With HP since 1979, Dave Hempstead has developed software for the HP 77400A Display Subsystem and for the HP 77410A Doppler Processor. He was born in Morristown, New Jersey and is a graduate of Rensselaer Polytechnic Institute (BSEE 1979). He is the coauthor of an *HP Journal* article on the HP 77020A Ultrasound Imaging System and is interested in real-time graphics software and Motorola 68000 Processor programming. Dave and his wife are residents of Methuen, Massachusetts and have a new baby. He likes sports car rallies, softball, and writing real-time 3-D graphics software. He also writes software for the PC in his church.

### Steven C. Leavitt



Steve Leavitt is a digital signal processing specialist who has been with HP's Andover Division since 1978. He was born in Portland, Maine, served in the U.S. Air Force, and graduated from the University of Maine with a BSEE degree in 1971. He worked on digital signal processing for the HP 77020A Ultrasound Imaging System, including the FFT Doppler processor, the color flow processor, and R-Theta scan conversion. He is named coinventor on two patents related to the R-Theta algorithm developed for the HP 77020A, and is coauthor of a symposium paper on the same subject. Before coming to HP he designed communication systems. Steve and his wife live in Hampstead, New Hampshire. In his leisure time he enjoys mountaineering, cross-country skiing, snowshoeing, and bicycling.

# The Role of Doppler Ultrasound in Cardiac Diagnosis

*In ultrasound imaging, a pulse of acoustic energy is transmitted into the human body and the strengths of the returning echoes from various organs and tissues are used to form an image on a display screen. Further information about blood flow and movement can be gained by measuring the shifts in the frequency of the echoes.*

by Raymond G. O'Connell, Jr.

**D**OPPLER ULTRASOUND represents an extension of the toolset that was described by Dr. Richard Popp in his article "A Physician's View of Echocardiography."<sup>1</sup> Although the technology is not new to medicine, its acceptance in the United States for cardiac diagnosis is relatively recent. This article will discuss a few of the clinical applications of Doppler ultrasound and compare alternative procedures.

## History of Ultrasound

For over twenty years ultrasound has been used to aid in the diagnosis of certain cardiac diseases. The first use was the time-motion study (called M-mode today). The technique involves transmitting a beam of ultrasound and plotting the intensities of the returning echoes across a strip of paper. As more and more lines are plotted, the locus of the motion of the echoes is plotted in time. This technique allows the diagnosis of stenotic valves, valve leaflet defects, and pericardial effusion.

Two-dimensional real-time imaging systems with Doppler capabilities were developed to enhance M-mode. The two-dimensional imaging systems caught on quickly and led to the demise of stand-alone Doppler equipment. Ultrasound imaging allowed the visualization of the heart over an entire cardiac cycle in real time. Reference 2 is a good review paper for the state of ultrasound medical techniques in 1982.

## Early Uses

The first Doppler systems available were continuous-wave systems that were used in the study of peripheral vascular disease (carotid arteries, veins, etc) and for the study of fetal heart rate. (Hewlett-Packard's first involvement in Doppler techniques was the HP 8021A Cardiotocograph introduced in 1971.) In the case of carotid artery examinations, the systems were designed to map the blood flows so that a two-dimensional presentation could be made that was very close to those obtained through X-ray techniques.

Pulsed Doppler technology followed. It was used in two fashions. First, it allowed the user to separate velocity information from several vessels in close proximity, as in the

neck. Second, it allowed the use of multiple timing gates which gave better information about the distribution of velocities within a vessel. Many of these systems employed a spectral analysis technique called a time-interval histogram for real-time analysis or processed the data off-line with a software fast Fourier transform (FFT) program. Two-dimensional imaging systems were introduced which allowed placement of a pulsed Doppler sample volume over a wide area. This equipment was designed for cardiac work and used the time-interval histogram spectral analysis approach, because of its low cost and speed.

Although articles were published on cardiac studies based on the use of pulsed Doppler techniques with this equipment, clinicians were slow to adopt Doppler ultrasound as an accepted aid in the diagnosis of cardiovascular disease because of the limitations of the technique, the

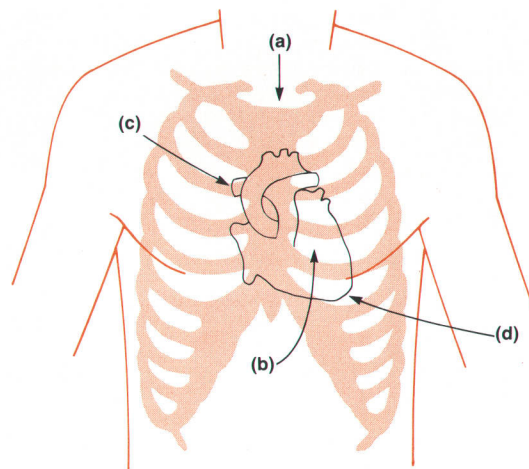

**Fig. 1.** Four transducer positions are used for obtaining Doppler information using a CW probe. (a) The suprasternal notch for ascending and descending aortic flow and pulmonary artery flow. (b) The left parasternal area for right ventricular inflow and outflow and pulmonary artery flow. (c) The right parasternal area (with the patient rotated in a right lateral decubitus position) for ascending aortic flow. (d) The cardiac apex for left ventricular inflow and outflow, ascending aortic flow, and right ventricular inflow.

limited number of applications, and its relative newness.

### Recent Developments

Within the past two years, cardiac Doppler ultrasound technology has been recognized as an important tool in evaluation of cardiac blood flow rates. Although it has been available for many years, it has not been considered as having clinical utility until the work of Hatle and Holen,<sup>3,4</sup> which demonstrated that valve pressure gradients could be quantified using Doppler ultrasound techniques.

In 1982, radionuclide and contrast angiography were preferred tools for the diagnosis of global ventricular function, identification of regurgitant valvular cardiac lesions, identification of intracardiac shunts, and assessment of coronary artery disease.<sup>2</sup> Today, ultrasound techniques are extremely successful in aiding the diagnosis of many cardiac abnormalities. The use of ultrasound in the diagnosis of coronary artery disease has had little success, except in pediatrics. Coronary angiography still provides the critical information for assessment of coronary function.

### Technical Limitations

The use of the Doppler effect in ultrasound measurement of blood flow has some limitations. There are two important aspects to the Doppler equation (see article, page 26) that must be considered where evaluation of cardiac disease is concerned. The first is the angle between the flow velocity of interest and the incident ultrasound beam. The most accurate velocities are measured when the angle is very small. However, when searching for certain cardiac anomalies such as high-velocity jets caused by stenotic, regurgitant, or shunt lesions, or defects in the heart, the exact angle

of flow is unknown and movement or rotation of the transducer is necessary until the location of the highest maximum velocity is obtained.

The other important aspect of the equation is the proportional relationship between the frequency used to interrogate the blood flow and the resultant frequency shift. In pulsed Doppler systems, the maximum measurable shift is limited by the rate of the ultrasound pulses sent out. For example, assume that a pulsed Doppler system is sampling flow from a vessel or heart chamber at a depth of 12 cm. Further assume that the speed of sound in body tissue is approximately 1540 m/s and the frequency of the beam is 2.5 MHz. Given the depth, the maximum pulse rate is 6.4 kHz. This means that the maximum measurable frequency shift is 3.2 kHz if the Nyquist criteria is observed. This shift corresponds to a blood flow velocity of about one meter/second, assuming an angle of zero degrees between the transducer and the flow direction. However, the velocities associated with many valvular defects are much higher, 3 to 5 m/s in some cases. For this reason, continuous-wave (CW) Doppler ultrasound is used. The trade-off here is between the measurement of flow at a selected depth, available from pulsed Doppler measurements, and the maximum velocities obtained from CW Doppler techniques. Use of both techniques during an examination has become an accepted practice because of the importance of determining severity as well as location of the disease. Fig. 1 shows common cardiac "windows" used in obtaining signals from the numerous areas of interest of the heart. Fig. 2 illustrates how the two sides of the heart function normally.

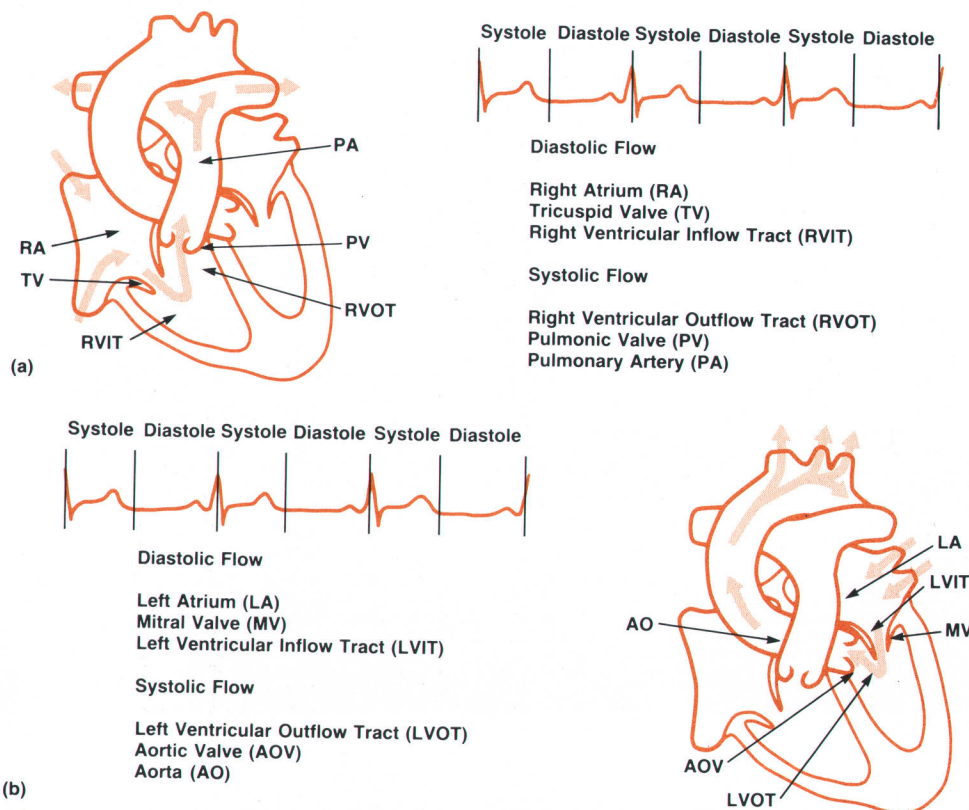

**Fig. 2.** Normal cardiac flow. (a) The right heart. Blood enters the heart through the vena cavae, which empty into the right atrium. Flow then proceeds from the right atrium through the tricuspid valve to the right ventricle during diastole. Systolic flow occurs when blood is ejected from the right ventricle through the pulmonic valve to the main pulmonary artery. (b) The left heart. Freshly oxygenated blood from the lungs returns to the heart via the left atrium. Flow then proceeds from the left atrium through the mitral valve to the left ventricle during diastole. Systolic flow occurs when the left ventricle pumps blood through the aortic valve back into the circulation system.

## Clinical Applications

Doppler echocardiographic systems are of little use unless they can determine the necessity for surgical intervention, drug treatment, or other therapy. The following is a list of several disease states in which Doppler measurements fulfill a critical diagnostic role:

- Valvular stenosis and regurgitation:
  - Mitral
  - Aortic
  - Tricuspid
  - Pulmonic
- Prosthetic valve function
- Congenital heart disease:
  - Ventricular septal defects (VSD)
  - Atrial septal defects (ASD)
  - Patent ductus arteriosus (PDA)
  - Coarctation of the aorta.

## Valvular Stenosis

The degree of valvular stenosis has traditionally been diagnosed in the catheterization laboratory by measuring the pressure drop across the valve. Pressure measurements are obtained by inserting pressure catheters into the right brachial vein and the left femoral artery. Pressures across the tricuspid valve and the pulmonic valve can be measured directly with the venous catheter by weaving it through each valve and measuring pressures as the catheter is pulled back through the valve.

In a similar fashion, the pressure across the aortic valve

can be measured by pushing the arterial catheter around the aortic arch and through the aortic valve into the left ventricle. Pressure across the mitral valve cannot be measured in this fashion because the catheter must be forced against the flow of blood and thus cannot be easily positioned behind the valve.

To obtain mitral valve pressure drop, pulmonary wedge pressure is measured. In this procedure, a venous balloon catheter is floated or sailed up the pulmonary artery until it wedges as the pulmonary artery size decreases. This pressure value is used for the left atrial pressure behind the mitral valve since the pressure drop across the lungs is very small. To guide the catheters and avoid the risk of puncturing vessels as the catheters are inserted, a fluoroscope is used to monitor the catheter position constantly. Cardiac catheterization has been considered routine procedure for determining the need for surgical replacement of cardiac valves.

Using Doppler equipment, a single noninvasive measurement can obtain the pressure drop across a stenotic valve. These dramatic results were the work of Holen, et al.,<sup>3</sup> who showed that Bernoulli's equation could be simplified to the following:

$$P_a - P_b = 4v_b^2$$

where  $P_a$  is the pressure proximal to the valve,  $P_b$  is the pressure distal to the valve, and  $v_b$  is the blood velocity at the valve exit point (highest velocity measured).

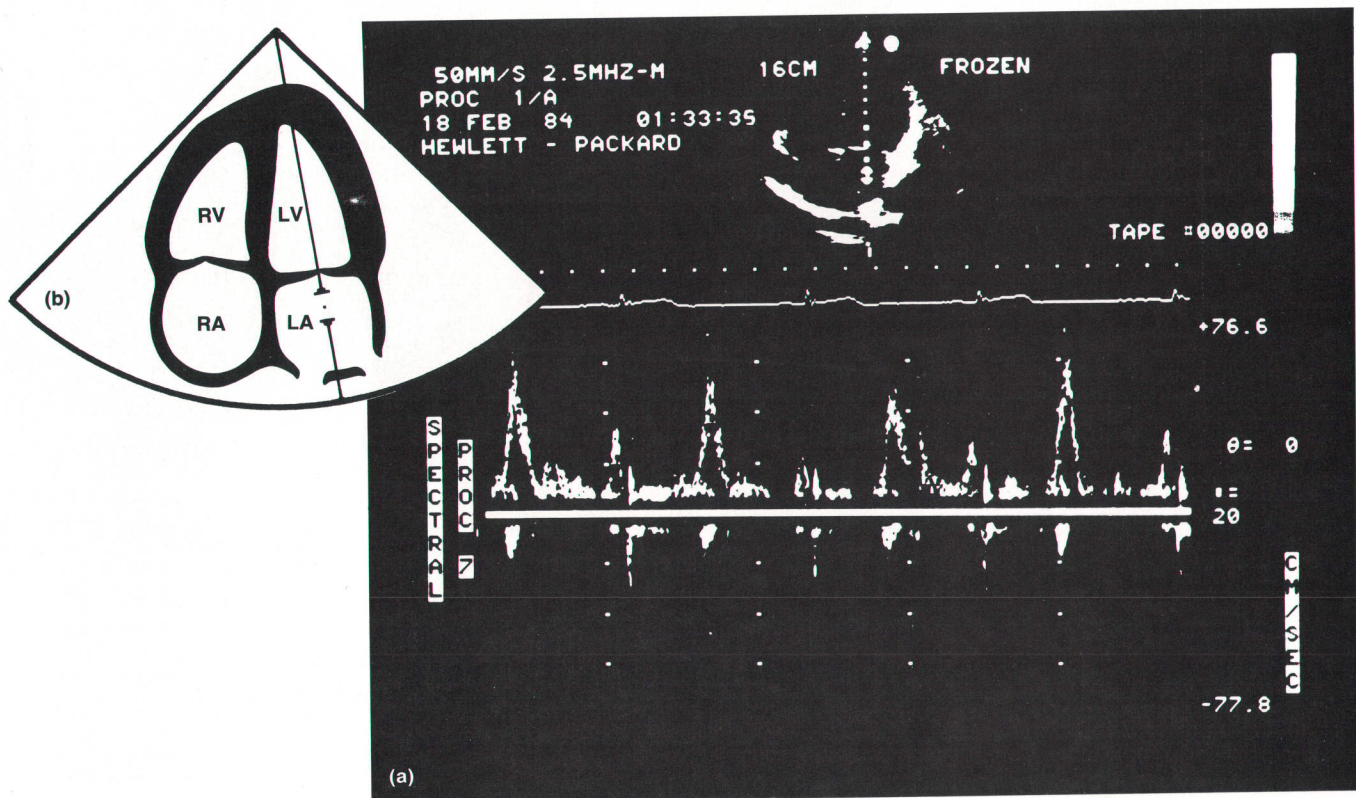

**Fig. 3.** (a) Pulsed Doppler display of the diastolic flow in the left atrium (LA) of the apical four-chamber view (b). This display shows an abnormal finding of high-velocity retrograde systolic flow and spectral broadening caused by mitral regurgitation.

This simplification is achieved by ignoring the flow acceleration and viscous friction elements in the original equation. If those terms were restored, the equation would have the following form:

$$P_a - P_b = \text{convective acceleration} + \text{flow acceleration} + \text{viscous friction}$$

$$= (K/2)(v_b^2 - v_a^2) + K(dv/dt)ds + R_v$$

where  $v_a$  is the blood velocity entering the valve or opening,  $K$  is a constant,  $dv/dt$  = acceleration of blood within the valve or opening,  $ds$  = flow path length, and  $R_v$  is a resistance coefficient. The simplification of this equation does not work for all conditions, but it has been clinically proven for orifice diameters above 3.5 mm and velocities above 3 m/s. A good summary of both the principles and clinical applications of Doppler ultrasound technology can be found in reference 4. In addition, numerous studies have been done to validate the accuracy of cardiac Doppler pressure calculations with positive results.<sup>5,6,7</sup>

Fig. 3 illustrates what a Doppler display contains in a pulsed mode. In this figure, the two-dimensional image, a four-chamber apical view, occupies the upper third of the black and white display. Below the image, a single ECG trace is displayed to allow correlation of flow events throughout an entire cardiac cycle. The bottom half is occupied by Doppler spectral data obtained with the sample

volume located in the left side of the heart. The spectral scale is calibrated in centimeters/second.

Fig. 4 illustrates a spectral display recorded using CW Doppler ultrasound. No image is generated in this mode because no range information is available. As can be seen from this figure, CW operation has a "flashlight" effect in that all blood flow interrogated by the beam contributes spectral data, compared to the pulsed mode where data from a single time sample along a single line contributes spectral information from a selected location.

Fig. 5 illustrates normal and abnormal flow patterns from the left ventricular inflow tract. For the case of aortic regurgitation, the blood velocity is so high at one point that aliasing occurs, that is, positive flow appears as negative flow.

### Cardiac Output

Most noninvasive procedures cannot accurately assess the function of the heart. Cardiac failure can cause stroke volume overloading, yet this overload can also occur in acute renal failure. Diuretics can remove all symptoms of cardiac failure without improving actual cardiac performance. For these and other reasons, it is important to be able to measure cardiac function not only for discovery of the patient's initial condition, but to track the patient's response to treatment.<sup>8</sup>

The traditional method for measuring cardiac output is by the thermodilution technique. A thermally sensitive catheter is placed to the right in the upper left side of the

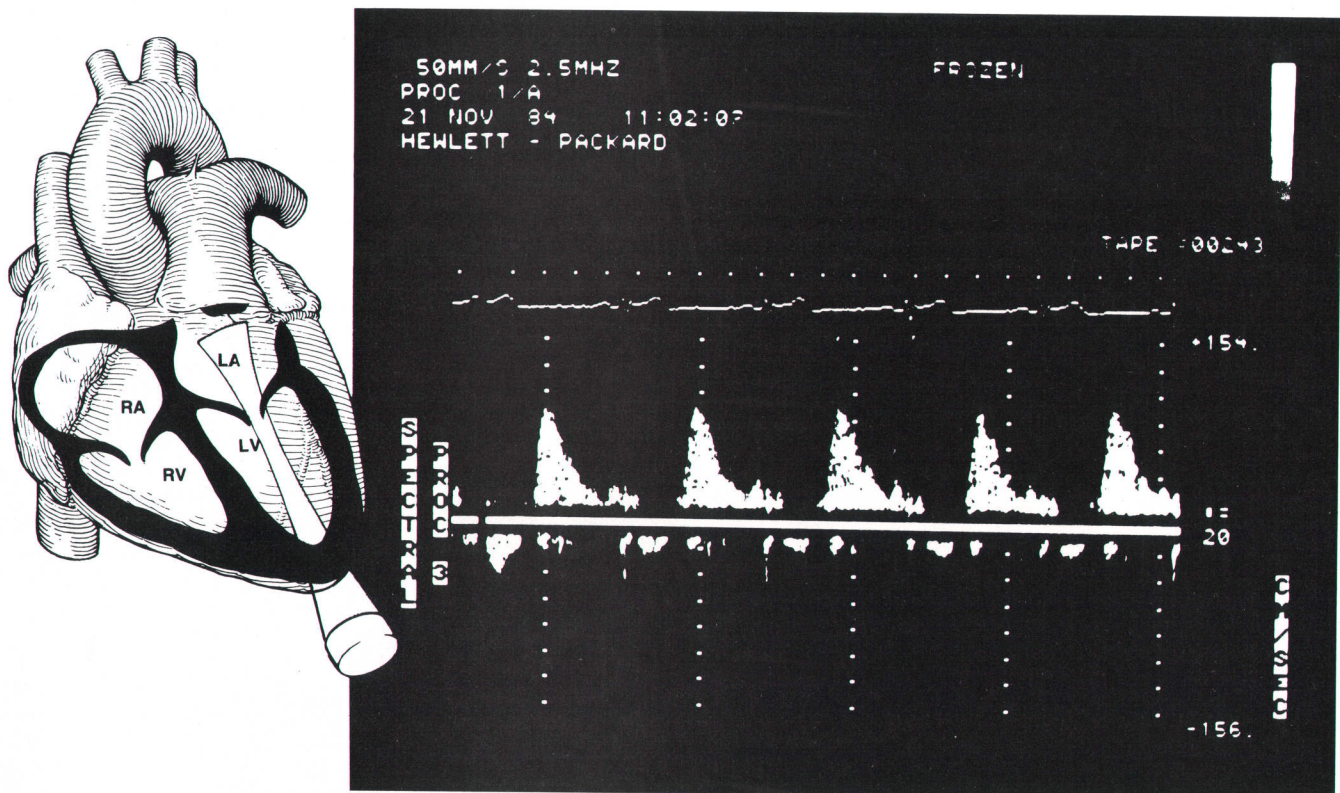
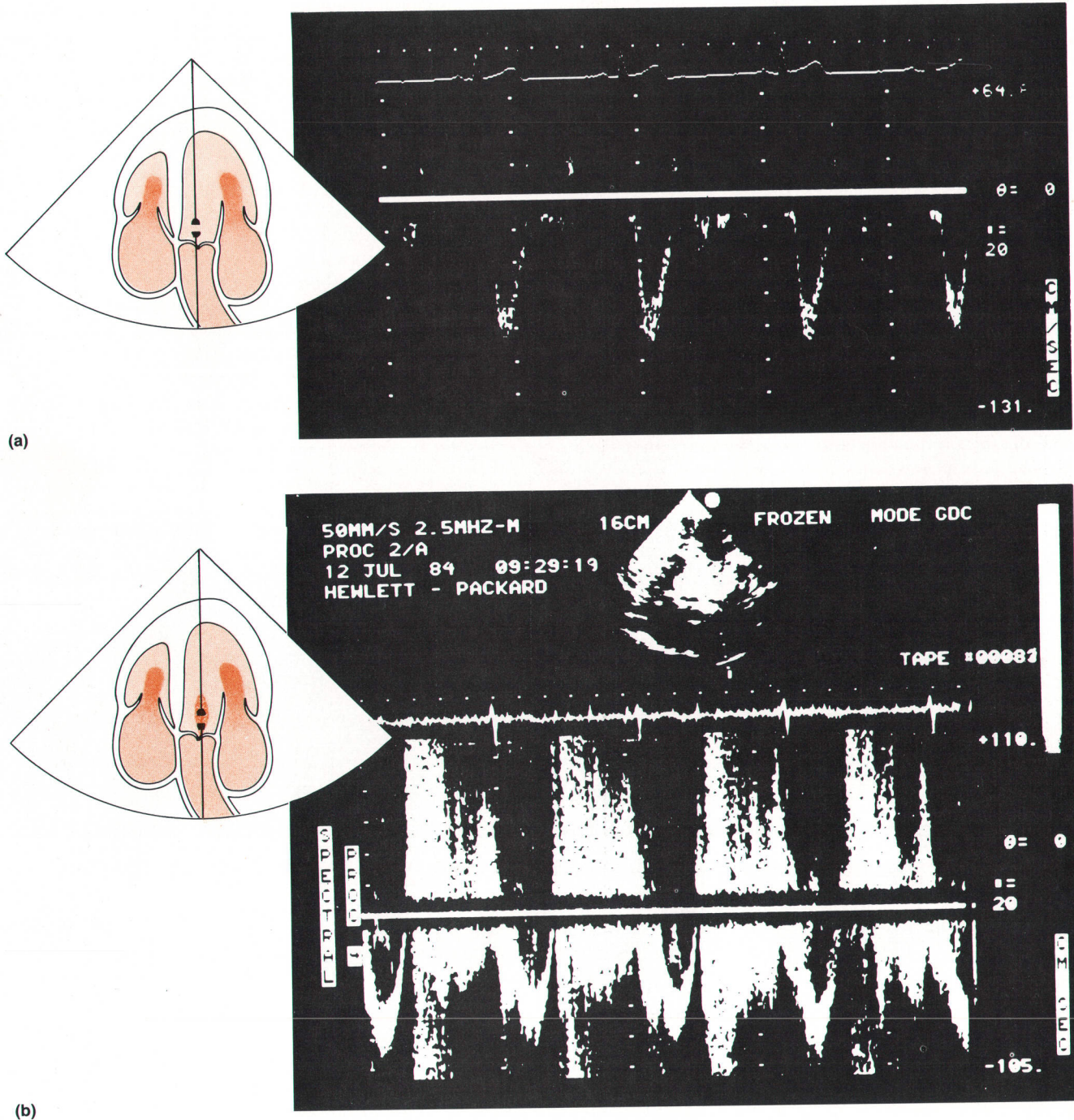

**Fig. 4.** CW Doppler display with beam focused on the left ventricular inflow tract and left atrium. This display shows an abnormal finding of high-velocity retrograde systolic flow and spectral broadening caused by mitral regurgitation and increased systolic flow velocity and spectral broadening caused by mitral stenosis.

heart. A premeasured volume of saline solution cooled below the temperature of the blood is injected into a central vein through a port in the catheter so that the solution flows into the right atrium. A thermistor located at the tip of the catheter monitors the initial blood temperature and temperature after injection of the cooled solution. By integrating the concentration curve and extrapolating this

curve beyond the point where the solution comes around the second time, cardiac output (volume flow) can be calculated. Because of the inherent risks associated with catheterization and fluid injection, a noninvasive method of evaluating cardiac output would be much preferred.

Cardiac output can be estimated with Doppler ultrasound techniques by measuring the mean velocity of flow through



**Fig. 5.** Pulsed Doppler displays showing (a) normal retrograde flow from aorta to left ventricle in diastole and (b) abnormal aortic regurgitation.



a vessel of known area and multiplying this stroke volume by heart rate. The primary limiting factor has been shown to be the inability to obtain an accurate flow cross-sectional area. Other limiting factors include accurate determination of the Doppler angle to flow velocity, and the assumption that laminar flow exists. This means that the absolute value for cardiac output cannot be obtained near a defective valve. In adults, this limitation seriously decreases the usefulness of Doppler cardiac output measurements for initial diagnosis. Doppler cardiac output is still a viable alternative in tracking a patient's response to treatment, however, because there are sites like the descending aorta where consistent measurements can be made reliably in almost all patients.<sup>9</sup> Some published comments about the use of Doppler techniques for evaluating cardiac output are:

"Because it is noninvasive, Doppler ultrasound measurement of cardiac output is ideal for repeated use in outpatients for monitoring progress, and Doppler ultrasound has been used for assessing the hemodynamic response to vasodilators in patients with heart failure."<sup>8</sup>

"These findings suggest that aortic blood flow measurements by Doppler velocimetry are useful clinically for the noninvasive evaluation of acute drug therapy in patients with heart disease."<sup>10</sup>

### **Congenital Heart Disease**

Congenital heart disease encompasses many of the same kinds of dysfunction that occur in acquired heart disease. Many people are born with abnormal blood flow patterns. The most common of these are openings in the septum of the heart that did not close in the normal development of the fetus. The most dramatic of these is the transposition of the great vessels in which the pulmonary and systemic systems are completely separated. Pulsed Doppler techniques are useful in locating and determining the direction and extent of abnormal flow, valvular abnormalities, shunt lesions such as patent ductus arteriosus, and ventricular and septal defects.

An extension to the ability to measure cardiac output is the quantification of left-to-right-side shunts whether they be in the septum or elsewhere. Two recent papers evaluating this technique stated:

"Our work in animals and in the clinical setting has attempted to demonstrate sources of error in using echo Doppler for noninvasive flow quantification. The multiple sampling site technique, while time consuming, suggests that echo Doppler can be used to quantify pulmonary and systemic flows and calculate flow ratios noninvasively."<sup>11</sup>

"We have demonstrated in this study that quantitative pulsed Doppler echocardiography can be successfully applied in the pediatric patient with isolated VSD to determine the magnitude of left-to-right shunt noninvasively."<sup>12</sup>

### **Summary**

This has been a short review of cardiac Doppler measurement technology. Use of Doppler ultrasound techniques as a screening procedure, and as an alternative to the catheterization lab in cases of suspected cardiovascular disease, has become a widely accepted practice because of its low risk, relatively low cost, and ease in obtaining critical clinical data. Every time a Doppler procedure can be performed in

place of a catheterization procedure, the patient not only has reduced risk, but also considerably less pain and expense (approximately one-fifth of the catheterization cost).

### **References**

1. R.L. Popp, M.D., "A Physician's View of Echocardiographic Imaging," *Hewlett-Packard Journal*, Vol. 34, no. 10, October 1983, pp. 13-16.
2. R.L. Popp, M.D., et al, "Optimal Resources for Ultrasonic Examination of the Heart," *Circulation*, Vol. 65, no. 2, 1982, pp. 423A-431A.
3. J. Holen, et al, "Determination of Pressure Gradient in Mitral Stenosis with a Non-invasive Ultrasound Doppler Technique," *Acta Medica Scandinavica*, Vol. 199, 1976, pp. 455-460.
4. L. Hatle and B. Angelsen, *Doppler Ultrasound in Cardiology*, Lea and Febiger, Philadelphia, 1982.
5. J.A. Requarth, et al, "In Vitro Verification of Doppler Prediction of Transvalve Pressure Gradient and Orifice Area in Stenosis," *The American Journal of Cardiology*, Vol. 53, May 1, 1984, pp. 1369-1373.
6. G.C. Adhar, M.D., and N.C. Nanda, M.D., "Doppler Echocardiography: Part II: Adult Valvular Heart Disease," *Echocardiography*, Vol. 1, no. 2, 1984, pp. 219-241.
7. L. Hatle, M.D., "Doppler Ultrasound in Mitral Regurgitation and Aortic Stenosis," *Practical Cardiology*, Vol. 9, no. 10, September 1983, pp. 73-84.
8. J. Rawles, M.D., and N. Haites, M.D., "Doppler Ultrasound Measurement of Cardiac Output," *Practical Cardiology*, Vol. 9, no. 8, July 1983, pp. 143-156.
9. L.H. Light, and G. Cross, "Convenient Monitoring of Cardiac Output and Global Left Ventricular Function by Transcutaneous Aortovelocity—An Effective Alternative to Cardiac Output Measurements," *Cardiac Doppler Diagnosis*, edited by M.P. Spencer, M.D., Martinus Nijhoff Publishers, Boston, 1983, pp. 69-80.
10. U. Elkayam, M.D., et al, "The Use of Doppler Flow Velocity Measurement to Assess the Hemodynamic Response to Vasodilators in Patients with Heart Failure," *Circulation*, Vol. 67, no. 2, 1983, pp. 377-383.
11. D.J. Sahn, M.D., and L.M. Valdes-Cruz, M.D., "Two-Dimensional Echo Doppler For Non-Invasive Quantification of Cardiac Flow: A Status Report," *Modern Concepts of Cardiovascular Disease*, Vol. 51, no. 10, October 1982, pp. 123-128.
12. J. Giroud, A.S. Pickoff, and P.L. Ferrer, "Pulsed Doppler Echocardiographic Quantification of Left-To-Right Shunts in Children With Isolated Ventricular Septal Defects," *Cardiac Doppler Diagnosis*, edited by M.P. Spencer, M.D., Martinus Nijhoff Publishers, Boston, 1983, pp. 227-234.

# Doppler Effect: History and Theory

by Paul A. Magnin

**T**HE DOPPLER EFFECT, sometimes thought of as a universal wave phenomenon, is in fact fundamentally different for light (or electromagnetic) waves and sound waves. For sound waves, one can derive the exact Doppler equation by imagining a stationary source of sound of some frequency and a listener at some distance from the source. If the listener is stationary (Fig. 1a), the listener experiences  $CT/\lambda$  waves in  $T$  seconds where  $C$  equals the speed of sound and  $\lambda$  is the wavelength. However, if the listener moves toward the source at a velocity  $v_l$  (Fig. 1b), the listener will experience an additional  $v_l T/\lambda$  waves in time  $T$ . The frequency the listener hears is just the number of waves per unit time or:

$$f_o = (CT/\lambda + v_l T/\lambda)/T = (C + v_l)/\lambda \quad (1)$$

The frequency at the source, which the listener hears while stationary, is just  $f_s = C/\lambda$ . The difference between the two perceived frequencies is referred to as the Doppler shift frequency. It can be expressed as:

$$f_d = f_o - f_s = f_s(1 + v_l/C) - f_s = v_l f_s/C \quad (2)$$

If the listener moves away from the source, the listener experiences fewer waves in time  $T$  and the frequency heard is lower than the source frequency. Equations 1 and 2 still hold, but the motion away from the source corresponds to a negative velocity. What is interesting is the difference between this case and the case where the source is in motion relative to a stationary listener (Fig. 2). When the source moves toward the stationary listener, the wavelengths are in effect shortened because between the time the crest of one wave is emitted and the succeeding crest is emitted the source has moved closer to the listener. If the source has a frequency  $f_s$  and a velocity toward the listener of  $v_s$ , then in the time it takes to emit one wave the source travels a distance  $v_s/f_s$ . The wavelength is compressed from the stationary source case of  $\lambda = C/f_s$  to  $\lambda_{hi} = C/f_s - v_s/f_s$ . The frequency that the listener hears is:

$$f_o = C/\lambda_{hi} = f_s C/(C - v_s) \quad (3)$$

and the Doppler shift frequency is:

$$f_d = f_o - f_s = f_s v_s/(C - v_s) \quad (4)$$

If the source moves away from the listener, the velocity term becomes negative and likewise the Doppler shift becomes negative. From equations 2 and 4 one can see that the motion of the source has a different Doppler shift frequency than the same motion of the listener. That is, for sound, it is not just the relative motion between source and listener that is important, but which one is in motion. Furthermore, as the velocity of the source approaches the

velocity of sound toward the listener, the Doppler shift frequency becomes infinite. Equations 2 and 4 can be combined to give the general Doppler equation for sound waves:

$$f_d = f_s(v_l + v_s)/(C - v_s) \quad (5)$$

This usually is simplified by assuming that  $v_s$  is small compared to  $C$ . Therefore:

$$f_d = f_s(v_l + v_s)/C, \text{ for } v_s \ll C \quad (6)$$

The situation is fundamentally different in the case of Doppler shifts of light waves. The difference stems from Einstein's Theory of Relativity, which states that the speed of light is a constant in all reference frames. Since light needs no material medium to support its propagation, its speed relative to the source or observer is always the same. Therefore, it is only the relative motion between the observer and the source that determines the Doppler shift frequency. The Doppler shift frequency for light predicted by Einstein's theory is:

$$f_d = [f_s(1 - v_{ls}/c)/\sqrt{1 - (v_{ls}/c)^2}] - f_s \quad (7)$$

where  $c$  is the velocity of light and  $v_{ls}$  is the relative velocity of the source and observer and  $v_{ls}$  is positive if the source and observer are moving away from each other. It is fairly easy to see that for the case where the source and listener velocities are small compared to the velocities of sound and light, equations 6 and 7 are approximately the same.

## Ultrasonic Doppler Blood Flow Measurements

It was recognized that ultrasonic waves, similar to those used in submarine sonar systems, could be used to locate structures in the body shortly after World War II. It became apparent that one could receive not only large echoes from

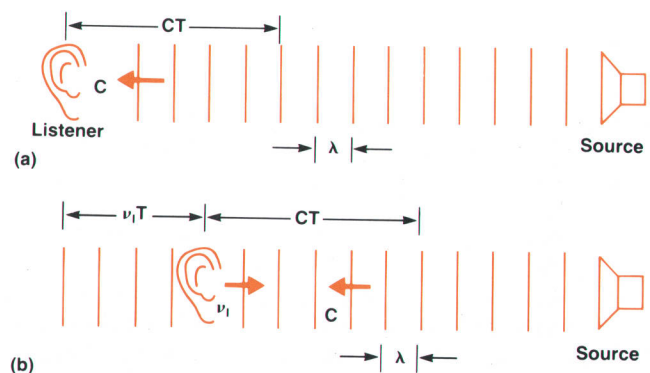

**Fig. 1.** (a) A stationary listener hears  $CT/\lambda$  cycles from a stationary sound source in time  $T$ . (b) If the listener moves toward the stationary source at velocity  $v_l$ , the listener hears an additional  $v_l T/\lambda$  cycles in time  $T$ .

internal structures but also tiny echoes scattered from moving blood. The primary scattering site in the blood that produces echoes is the red blood cell. The size of the echoes from red blood cells is related to the scattering cross section of the cell, which is on the order of four micrometers. The scattering cross section of a platelet is 1000 times smaller and does not contribute significantly to the Doppler-shifted energy. Leukocytes are not present in sufficient numbers to influence the backscattered signal from the red blood cells.

The incident ultrasonic pulse extends over many red blood cells and the reflected signal received at any given range is the sum over the effective resolution cell of the complex vectors produced by each red blood cell. There are five million red blood cells in a cubic millimeter of blood (give or take a few), and these phasors do not arrive at the transducer in phase, although they are coherent because they vary in unison. This coherent integral is analogous to the same phenomenon that results in the speckled appearance of laser light images (see reference 1 for more details about ultrasonic speckle). If one assumes that the position of a given red blood cell is a random variable with a uniform distribution, the amplitude of the backscattered signal will also be a random variable distributed according to a Rayleigh distribution. Although the phase and magnitude of the Doppler echoes are random variables, they do change in a reasonably orderly fashion. In the case where the red blood cells are moving through the sample volume at a constant velocity toward the transducer, the frequency of the echoes will increase (most of the time).

### CW Doppler Measurements

The first reported application of the Doppler effect to medical ultrasound took the form of a continuous-wave (CW) Doppler velocity measurement.<sup>2</sup> These systems typically use a transducer made with two piezoelectric crystals for transmitting and receiving the ultrasonic wave. The transmitted wave is sinusoidal at a frequency usually between 2 MHz and 10 MHz. Attenuation of ultrasound in the body tends to increase linearly with frequency, which dictates lower frequencies to obtain greater penetration. Higher frequencies, on the other hand, provide narrower beams for a given transducer size. When the transmitted pulse enters the body, reflections occur at the tissue interfaces in the path of the beam. If the interfaces are stationary, the reflected signal returns to the receiver at the same frequency as the transmitted signal, albeit attenuated by the intervening tissue. However, if the echo returns from structures such as a heart wall or a group of red blood cells that are moving, the returning signal receives a Doppler shift. What is interesting is that the Doppler shift is twice that predicted by equation 2 or 4. The reason is that the structure causing the reflected echo is acting as both the listener and the source. Since the structure is in motion, the transmitted frequency it perceives is Doppler shifted according to equation 2. The echo that leaves the structure is shifted again, since it now acts like a source which is in motion relative to the stationary receiver, according to equation 4. Since only the component of the velocity directed toward or away from the transducer contributes to the Doppler shift frequency, one must scale the frequency shift by the cosine

of the angle between the structure's velocity vector and the line connecting the structure and the transducer. The Doppler shift can then be expressed:

$$f_d = (2Vf_s/C) \cos\theta, \text{ for } V \ll C \quad (8)$$

where  $V$  is the structure's velocity,  $\theta$  is the angle between the ultrasonic beam and the structure's velocity vector,  $f_s$  is the frequency of the incident ultrasonic pulse, and  $C$  is the velocity of sound in the body.

A continuous-wave blood velocity measuring instrument typically extracts the Doppler shift frequency by mixing the received signal with the local oscillator that produced the transmitted signal. After filtering out the sum term, one is left with the frequency difference between the transmitted signal and the received signal, which is the Doppler shift frequency.

It turns out that for velocities present in the body and for the frequencies typically used, the Doppler shift frequencies from blood occur in the audible range. Heart and vessel walls usually produce shifts in the 0-to-1200-Hz range, normal blood flow causes shifts in the 0-to-5-kHz range, and jets from septal defects and malfunctioning valves generate shifts in the 5-to-20-kHz range. Early CW instruments simply played the Doppler shift frequencies into a speaker. The first refinement of these primitive instruments

## Johann Christian Doppler

Johann Christian Doppler's paper "On the Colored Light of Double Stars and Some Other Heavenly Bodies" was delivered to the Royal Bohemian Society of Learning in 1842. In spite of the current significance of his contribution to science, he was so little regarded by his colleagues that today we know few details of his personality. He was born in Salzburg, Austria in 1805 and died at the early age of 49 of pulmonary disease. He worked in relative isolation as a professor of elementary mathematics and practical geometry at the State Technical Academy in Prague.

Buys Ballot, a contemporary of Doppler, published his doctoral thesis in 1844 stating that he did not believe Doppler's theory could explain the color of double stars. It was Ballot who felt Doppler's theory should be put to the test and he conducted the now famous experimental verification of the Doppler effect. He chose to use sound waves rather than light waves, since the speed of sound, being much slower than the speed of light, was predicted by Doppler's theory to result in a much larger frequency shift. Ballot was loaned a locomotive and a flatcar which was to carry a trumpet player able to play a note with perfect absolute pitch. A second musician, also with perfect pitch, stood in the train station and listened as the trumpet player passed. The stationary musician heard the the trumpet note one half tone higher as the train approached and one half tone lower as the train passed. Although the experiment seemed to verify Doppler's theory, Ballot published his account of the experiment in an article in which he voiced several objections to Doppler's theory. Rather than establishing Doppler's theory, Ballot's article seems to have discredited Doppler for many years.

### Reference

1. D.N. White, "Johann Christian Doppler and His Effect—A Brief History," *Ultrasound in Medicine and Biology*, Vol. 8, no. 6, 1982, pp. 583-591.

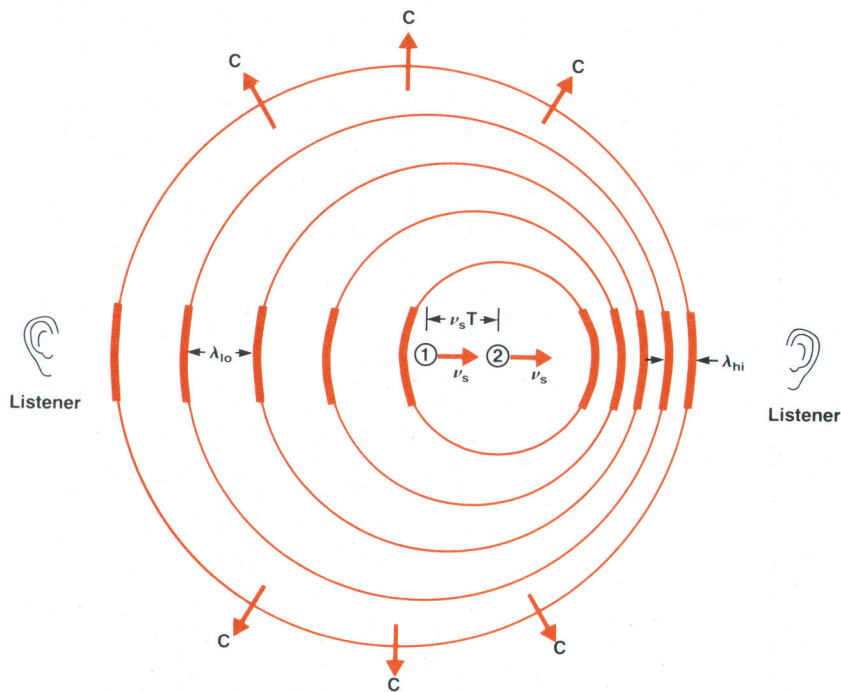

**Fig. 2.** Effect of a moving source on wavelength (and hence frequency) of the emitted sound wave. The outermost circular wavefront was emitted when the source was at position 1 and the innermost circular wave front was emitted at position 2. (The wave fronts are circular because the sound propagates in all directions at the same velocity after it is emitted by the source.) Thus, a stationary listener on the left hears a frequency lower than the source frequency and a listener on the right hears a higher frequency than the source.

was to process the received signal in quadrature so as to allow the differentiation of positive frequency shifts from negative frequency shifts. Positive Doppler shift frequencies correspond to structures moving toward the transducer (upper sideband of the received signal) and negative frequencies correspond to structures moving away from the transducer (lower sideband of the received signal). These improved instruments played positive frequencies in one channel of a stereo pair of speakers and negative frequencies in the other. Since echoes returning from red blood cells come from the entire volume contained in the transducer beam and not a single point, there is in fact a spectrum of Doppler shift frequencies returning to the transducer. As it turns out the human ear is remarkably adept at recognizing frequencies and bandwidths of signals in the presence of wideband noise. These systems were clinically very successful once operators were trained enough to recognize the normal Doppler shift sounds from abnormal flow patterns.

The next enhancement to the CW Doppler system was the addition of a crude spectrum analyzer. The first spectral displays were time-interval histograms made by measuring the times between zero crossings of the Doppler shift waveform. The zero crossing times (or time intervals) are then lumped into bins and displayed as a histogram that gets updated many times in a heart cycle. These histograms served as a crude version of a real-time spectrogram. Before long, fast Fourier transform (FFT) and chirped z-transform circuits were feasible that could calculate 128-point spectra in a few milliseconds, and these replaced the less accurate time-interval histograms.

### Pulsed Doppler Measurements

The major limitation of the continuous-wave instruments is that they are sensitive to motion, in particular, blood flow along the entire length of the ultrasonic beam. This

can lead to ambiguities, since the position of any aberrant flow cannot be localized in range. To overcome this problem, the first pulsed Doppler system was developed.<sup>3</sup>

Pulsed Doppler systems transmit a short sinusoidal burst instead of a continuous sinusoidal wave. By gating the received signals to correspond to the pulse's time of flight to the point of interest, one can interrogate a small sample volume instead of the entire length of a beam. Since these pulsed Doppler instruments require sampling the returning echoes at a fixed time after the burst is transmitted, it is possible for the higher-frequency Doppler shifts to alias to lower frequencies. The pulsed Doppler system and the aliasing can be more easily understood if one considers the echoes returning from a moving wall as shown in Fig. 3a. Samples of the Doppler shift waveform are obtained by sampling the echo at a fixed time after the pulse leaves the transducer. As the wall advances the phase of the sample changes corresponding to the amount the wall has moved between successive samples. If the wall moves quickly enough to advance the phase of the sample by more than 180 degrees, as in Fig. 3b, the sampled Doppler shift waveform is aliased to a lower frequency. This is a severe limitation of pulsed Doppler instruments. As the depth at which one wishes to interrogate blood flow increases, the length of time between the transmitted pulse and the sample gate increases. Each echo must be allowed enough time to return from the maximum depth of interest before the next burst is transmitted to prevent ambiguous range information. The burst repetition frequency in turn determines the maximum Doppler shift frequency that can be detected without aliasing, a result of the Nyquist phenomenon. As a result, a trade-off between maximum sample volume depth and maximum unaliased blood velocity exists that did not occur with the CW system.

Pulsed Doppler systems have some other interesting properties which are related to Heisenberg's Uncertainty

Principle. The problem with pulsed Doppler systems is that to localize the sample volume accurately in space, one requires a shorter transmitted burst. This corresponds to a wider transmitted bandwidth. However, as Heisenberg predicts, when our ability to localize the sample volume in space increases, our ability to measure the velocity accurately decreases. This can be seen if one examines the pulsed Doppler system in the frequency domain. If the transmitted pulse shape is assumed to have a Gaussian amplitude envelope, the time domain signal can be written:

$$p(t) = \text{Gaus}\left(\frac{t-t_0}{\sigma\sqrt{2}}\right) \times \sin[2\pi f_s(t-t_0)] \quad (9)$$

where  $\sigma$  = standard deviation of the Gaussian envelope,  $t_0$  = time of flight to and from the sample volume of interest, and  $\text{Gaus}(x) = (\sigma\sqrt{2\pi})^{-1} \times \exp(-x^2)$ . Since the pulse is repeated at the pulse repetition frequency (PRF), the insonifying signal can be described as:

$$p(t) = \sum_{n=-\infty}^{\infty} \delta(t - \text{PRI} \times n) * \left\{ \text{Gaus}\left(\frac{t-t_0}{\sigma\sqrt{2}}\right) \times \sin[2\pi f_s(t-t_0)] \right\} \quad (10)$$

where  $\text{PRI} = \text{pulse repetition interval} = 1/\text{PRF}$ .

The magnitude of the Fourier transform of the time domain signal in equation 10 can be written:

$$P(f) = K \sum_{n=-\infty}^{\infty} \delta(f - n/\text{PRI}) \times \{ \text{Gaus}(\sigma f \sqrt{2}) * \delta_\delta(f/f_s) \} \quad (11)$$

where  $K$  is a gain constant,  $\delta(x)$  is the Dirac delta function, and  $\delta_\delta(x)$  is an asymmetric delta function where the impulse function assumes the sign of the argument. Equation 11 is drawn in Fig. 4a for  $f_s = 8 \text{ PRF}$ . This is the spectrum returned from stationary objects and is referred to as the clutter spectrum. Optimistic souls may assume that the spectrum of the signal with Doppler information included

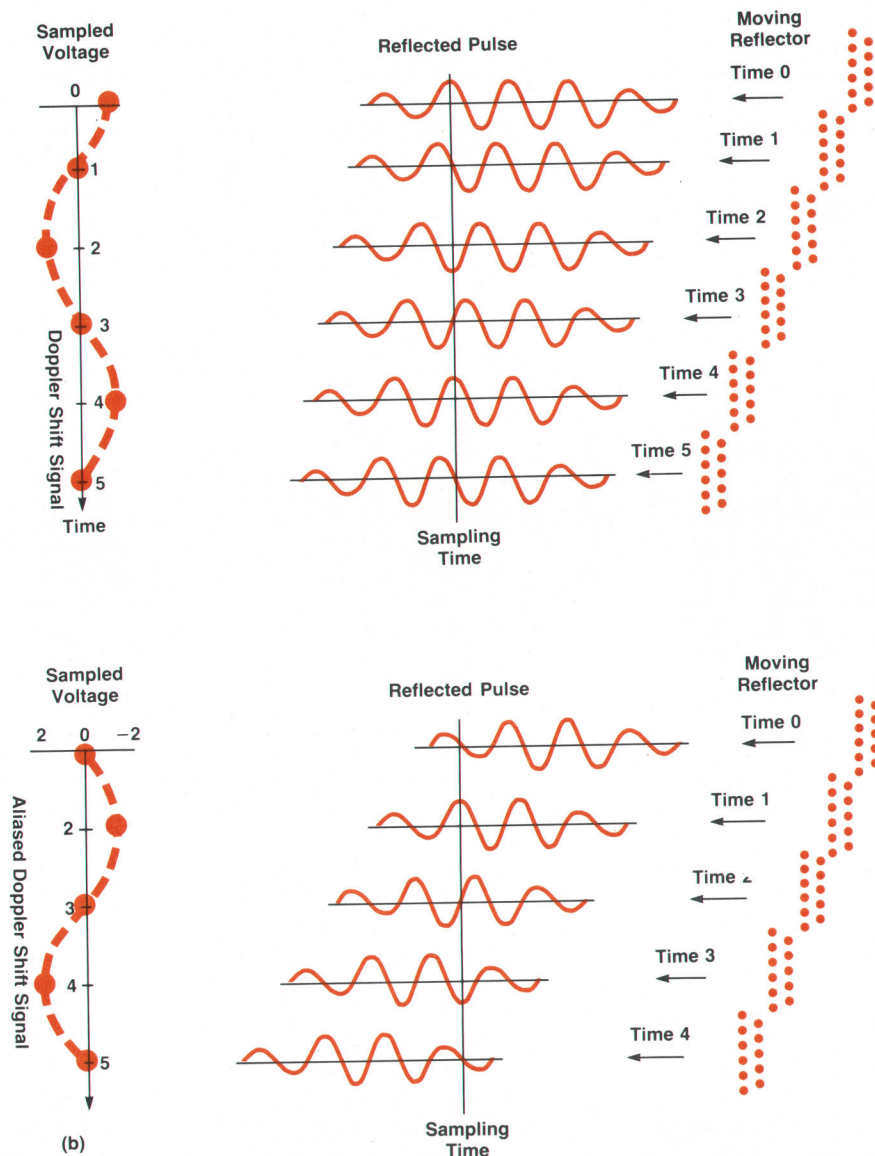

**Fig. 3.** (a) Sampled voltage for Doppler shift caused by an echo from a slowly moving wall. (b) If the wall moves fast enough to shift the reflected wall by more than 180 degrees between sample points, the frequency shift is aliased to a lower frequency.

is simply the superposition of a clutter spectrum with another identical spectrum (perhaps with lower magnitude) shifted by the Doppler shift frequency. Such a spectrum is drawn in Fig. 4b. This spectrum shows only a single Doppler shifted signal at each of the clutter harmonics. This, however, is emphatically not the case.

An idealized spectrum of what one would actually see is shown in Fig. 4c. Each clutter harmonic produces its own Doppler shift frequency which is not the same "difference frequency" as each of the other clutter harmonics (recall the  $f_s$  term in equation 6). This leads to the somewhat disconcerting fact that for a single particle moving at a single and constant velocity, a spread of Doppler shift frequencies will be received.

As the velocities increase, the frequency shifts from the clutter harmonics increase. The difference between each Doppler component and its respective clutter harmonic is proportional both to the frequency of the clutter harmonic and to the velocity of the scatterers. A spread of shift frequencies is measured whose bandwidth is proportional to the bandwidth of the transmitted pulse and to the velocity of the scatterer. What is then measured as the Doppler shift frequency for a single scattering site with a constant and uniform velocity is the summation of the Doppler harmonics weighted by the scaled version of the Gaussian bandwidth of the transducer and electronics, or:

$$D(f) = K \times \text{Gaus} \left[ \frac{\sigma\sqrt{2}}{K_1} (f - f_s K_1) \right] \times \sum_{n=-\infty}^{\infty} \delta(f - nK_1/\text{PRI})$$

where  $K_1 = (2V \cos \theta)/C = f_d/f_s$ . This leads to two interesting observations. First, if a narrow band of Doppler frequencies is desired to represent only a narrow range of scatterer velocities, then it will be necessary to narrow the bandwidth of the transmitted pulse. This can be done either by increasing the number of transmitted cycles or by filtering the input to the Doppler detector. In either case, the range resolution is degraded.

Another way to look at this position-velocity uncertainty trade-off is to picture each scattering site remaining in the ultrasonic sample volume for a finite length of time. The sample volume is most sensitive to the scattering site near its center and the sensitivity tapers off near the edges. As a result, the Doppler shift waveform has a low amplitude as the scattering site enters the sample volume, the amplitude increases as the site moves to the center of the volume, and as the particle passes through to the other side of the volume the amplitude again drops to zero. This behavior in effect windows the time domain waveform by convolving the sample volume with the impulse from the scattering site. The spectrum produced based on this windowed waveform and a single velocity becomes a band of Doppler shift frequencies. Furthermore, the faster the particle travels, the shorter the time window in the sample volume and the wider the band of frequencies produced. The second effect of this Doppler shift frequency spread is that aliasing will begin to occur at a frequency slightly different from the Nyquist rate, which is just the Doppler pulse repetition frequency divided by 2. Note what is involved here: aliasing from the higher clutter harmonics occurs before the nominal Nyquist frequency.

There is a second mechanism responsible for anomalous spectral spreading which is caused by the statistical nature of the signal scattered from red blood cells. Since the amplitude of the echo varies with the specific orientation of each red blood cell and since new red blood cells enter the sample volume and others leave the sample volume during the time required to obtain the samples of the Doppler shift waveform, the echo amplitude is modulated independently of the Doppler shift. This amplitude modulation creates sidebands in the received signal which overlap the Doppler shift sidebands. This has the effect of creating spurious Doppler shift information which tends to increase the apparent bandwidth of the Doppler spectrum.

In spite of the theoretical limitations, ultrasonic Doppler velocity meters have met with tremendous clinical success.

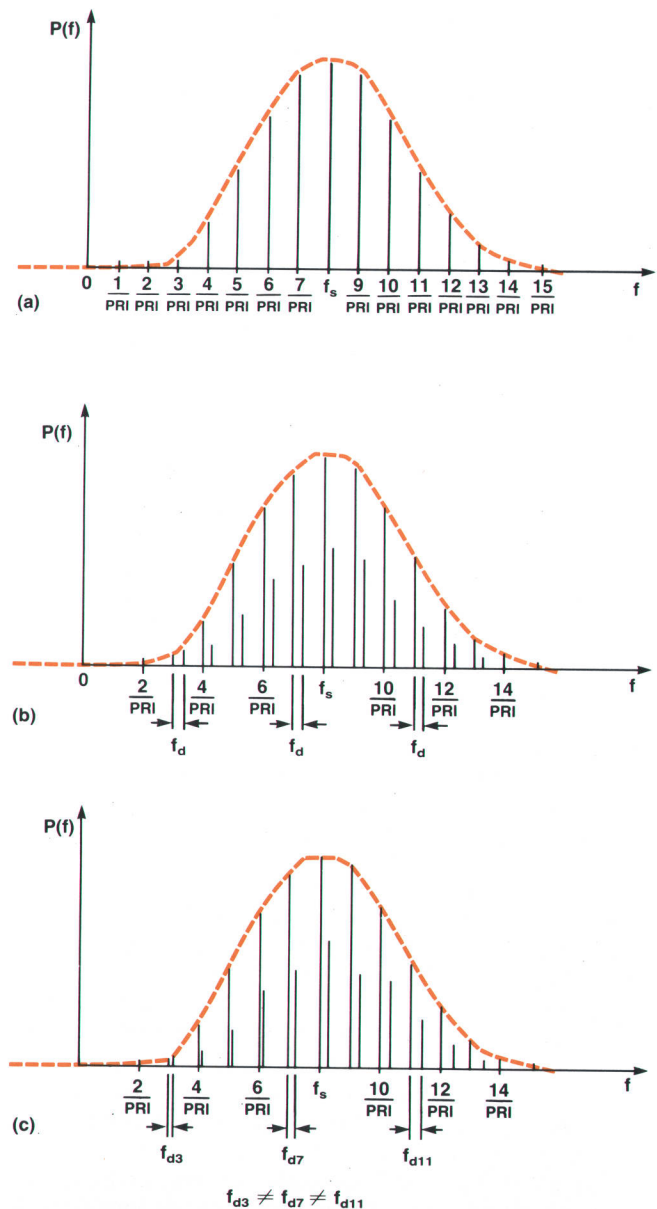

Fig. 4. (a) Clutter spectrum returned from stationary objects. (b) Smaller shifted spectrum superimposed on the clutter spectrum. (c) Actual Doppler spectrum (see text).

New systems incorporate both continuous and pulsed wave techniques to avoid the frequency aliasing ambiguities of the latter and the range resolution ambiguities of the former. Physicians tend to overlook the problem of spectral spreading and for the most part it has not proved to be a major drawback of the instrument. One remaining problem with commercial Doppler systems seems to be their sensitivity. Because of the weakness of the echoes from red blood cells, even the best commercially available systems can rarely acquire good Doppler signals at depths beyond 14 cm. Doppler systems also tend to be fairly cumbersome to use. The operator must move the sample volume to the position of interest and listen or look at the Doppler spectrum for a number of heart cycles to determine if abnormal flow is present. Searching for a jet from a ventricular septal defect or a regurgitating valve may require stepping the sample volume over a large area. This can become not only time consuming but tedious. The next step in the evolution of these Doppler blood flow instruments is to create a flow image by simultaneously processing the Doppler shifts

from every point in the image and coding the blood flow velocities in color. This will provide a visual impression of the flow at every point in the image in real time.

#### References

1. P.A. Magnin, "Coherent Speckle in Ultrasound Images," *Hewlett-Packard Journal*, Vol. 34, no. 10, October 1983, pp. 39-40.
2. S. Satomura and Z. Keneko, "A Study Examining the Heart with Ultrasonics," *Japanese Circulation Journal*, Vol. 20, 1956, p. 227.
3. D.W. Baker and D.W. Watkins, "A Phase Coherent Pulsed Doppler System Cardiovascular Measurement," *Proceedings—20th ACEMB*, Vol. 27, 1967, p. 2.

#### Bibliography

- P. Atkinson and J. P. Woodcock, *Doppler Ultrasound and its Use in Clinical Measurement*, Academic Press, New York, 1982.
- D.W. Baker, F.K. Forster, and R.E. Daigle, *Doppler Principles and Techniques, Ultrasound: Its Application in Medicine and Biology*, edited by F.J. Fry, Vol. 1, chapter 3, Elsevier Press, 1978.

# Power and Intensity Measurements for Ultrasonic Doppler Imaging Systems

by James Chen

**U**LTRASONIC DOPPLER SIGNALS are scattered echoes from red blood cells. These echoes are two to three orders of magnitude weaker than the echoes reflected from heart wall and body tissue. Even though those echoes have very narrow bandwidth, the signal-to-noise ratio is still significantly lower than that of the heart wall signal-to-noise ratio. To detect the weak Doppler signals, the system and transducer must be designed to be sensitive enough to detect low-level signals and simultaneously handle the high-level signals from slowly moving interfaces such as the heart wall. Therefore, when attempting to extract Doppler data, it is sometimes necessary to drive the transducer harder than when extracting normal ultrasound imaging information. However, this translates to a higher acoustic energy into the patient's body which must be carefully controlled to cause no adverse effects.

Thus, it was clear early in our system design that not only does the system have to be designed to have exit power and intensity below the generally accepted limits, but also its output has to be measured carefully to ensure that they are within those limits.

All of HP's acoustic output measurement procedures conform to the definitions and methods suggested by guidelines set by the American Institute of Ultrasound in Medicine and the National Electronic Manufacturer's Association. This ensures that we meet labeling requirements and

that we use the same terms and values as government regulatory agencies and other ultrasound medical equipment manufacturers. However, HP procedures do not follow the regulations literally because features particular to our system make literally following the guidelines very difficult. In some cases, this would yield misleading data.

There are two types of exposure parameters that must be measured. They are the total acoustic power and the intensity values measured at a particular point in the acoustic field. The former is a measure of the total acoustic energy delivered by a transducer per unit time. The latter is the amount of energy delivered to a unit area per unit time. Total power depends on how much electric energy is input to the transducer and how the transducer transforms it into acoustic (mechanical) energy. The intensity depends on the electric energy into the transducer, the total acoustic energy out, and how the energy is focused to a particular spot. The total power is measured with a force balance, and intensities are measured with a hydrophone.

#### Total Power Measurement with a Force Balance

Fig. 1 schematically describes the concept of a radiation pressure measurement. Basically, when a sound wave propagates through the liquid, it generates a dc pressure at the target as a result of the fluid density variation during pressure wave propagation. This is the radiation pressure

associated with the pressure wave. If a target is large enough, it receives an uplifting force which comes from the entire radiation pressure field. This force causes the target to weigh less when the pressure wave is present than when it is not. A balance can be used to read out this difference which is directly related to the total acoustic power. Ideally, if pure water is used as the propagation medium, one watt of acoustic power generates a weight loss of 68 mg, which can be derived as follows, where  $P_T$  = the total power in watts,  $m$  = the mass in kilograms,  $C$  = the ultrasonic velocity in meters per second, and  $a$  = the acceleration in meters per second squared:

$$F = P_T/C = ma \quad (1)$$

Therefore,  $m = P_T/aC$  and for  $P_T = 1$  watt:

$$m = 1/(9.8 \times 1,494) = 6.83 \times 10^{-5} \text{ kg} = 68.3 \text{ mg}$$

The accuracy of a force balance can be affected by several factors, such as absorption by the target, standing-wave formation, and convection current reduction. To ensure their accuracy, our force balances are calibrated with the use of standard quartz transducers. The quartz transducers are calibrated for total acoustic power at the U.S.A. National Bureau of Standards to within 3% accuracy. To calibrate the force balance, the standard transducer is positioned at the force balance window. Since it emits a pressure wave of known acoustic power, the weight loss reading from the balance divided by the known total acoustic power gives the calibration coefficient in mg/watt.

The force balance provides a convenient means to measure total acoustic power from an ultrasonic device. However, prudence must be exercised during the testing to ensure that the measurements are meaningful. For example, this technique can be used to measure sector imaging mode and M-mode output power. Because this method really measures the radiation pressure from an acoustic wave, the M-mode beam should be aimed straight at the target and the sector mode result must be corrected for the fact that for a portion of the scanning, the acoustic beam is hitting the target obliquely.

### Intensity Measurement with a Hydrophone

Intensity is a measure of power concentration at a spot. Since it has a direct relationship with tissue damaging mechanisms such as heating and cavitation, this parameter has been of great concern to health physicists. Intensity measurement in medical ultrasound is complicated be-

cause it is generally not constant throughout a time period, and is not uniform spatially. Thus, ultrasonic intensities must be further defined. The three commonly used intensities are:

- Spatial peak temporal average intensity (SPTA)
- Spatial peak pulse average intensity (SPPA)
- Spatial average temporal average intensity (SATA).

To measure these intensities, a passive listening device is positioned in the acoustic field to measure the pressure at various locations. This listening device, or hydrophone, transforms the pressure waves received into voltage waveforms which can be displayed on a CRT. When the hydrophone is calibrated, the measured voltage waveform can be used to derive the intensities.

Various types of materials can be used to fabricate hydrophones. Each has its advantages and disadvantages, the discussion of which is beyond the scope of this article. Our attention will focus on calibration and intensity measurement using PVDF (polyvinylidene difluoride) hydrophones.

### Hydrophone Calibration

In our case, a hydrophone is used as a pressure-to-voltage transformer. "What is the pressure/voltage transfer ratio?," "How flat is the response as a function of frequency?," and "How linear is the response as a function of intensity?" are key questions whose answers are linked to the accuracy of intensity measurement. The piezoelectric properties of PVDF are stable and rather linear over a large dynamic range. The hydrophones must be able to withstand the acoustic field put out by medical ultrasound equipment and they should have a flat frequency response. However, our experience with commercially available hydrophones indicates that sensitivity can drift unexpectedly and that the frequency response is not flat and can vary with time. This suggests that hydrophone calibration must be included as an integral part of intensity measurement.

The way to calibrate a hydrophone is to position the hydrophone in a known pressure field and read the hydrophone output voltage. For example, a hydrophone gives a voltage reading  $v$  when it is positioned in a pressure  $p(x,y,z)$ . The ratio  $v/p(x,y,z)$  is the calibration coefficient of that hydrophone. Two methods are generally used to establish a known pressure intensity  $p(x,y,z)$ . One is based on self-reciprocity, the other on radiation pressure. The basic principle behind the first method is that if the input and output impedance conditions are properly met, the acoustic field in a particular location can be derived from an appropriately designed round-trip driving/receiving voltage measurement. The other method is based on the concept that the total acoustic power is an integration of the acoustic intensities measured over a field profile, and the same total power can also be determined by a radiation pressure measurement using a force balance. This discussion will be limited to this second method.

The total power from a transducer is an integration of the intensities measured at various locations in an acoustic field profile. For a two-dimensional field:

$$P_T = \iint \frac{p^2(x,y)}{Z} dx dy \quad (2)$$

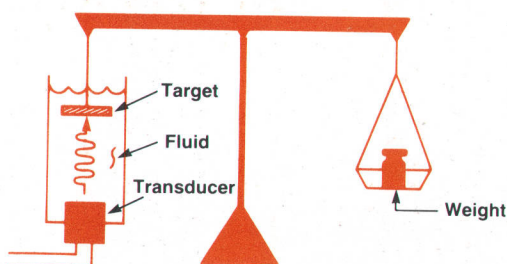

Fig. 1. Measuring radiation pressure with a force balance



where  $Z$  is the acoustic impedance. This can further be reduced to:

$$P_T = \frac{p^2(x_o, y_o)}{Z} C_1 \quad (3)$$

where:

$$C_1 = \iint \frac{p^2(x, y)}{p^2(x_o, y_o)} dx dy$$

and  $p(x_o, y_o) = \sqrt{P_T Z / C_1}$ , which is the absolute peak pressure amplitude in a pressure field. The total power can be measured with a force balance as has been described. The acoustic impedance  $Z$  is known. The constant  $C_1$  is an integration of the square of the normalized pressure profile, which can be measured by an uncalibrated hydrophone across a profile. Thus, the equation for  $p(x_o, y_o)$  above allows us to calculate a pressure intensity at a point in the field. Measuring the output of a hydrophone positioned at that point can be used to determine the calibration constant for that hydrophone. The same quartz transducers previously mentioned are used regularly to generate the intensity field to calibrate our hydrophones.

### Frequency Response Calibration and Compensation

For the CW Doppler mode, nearly single-frequency pressure waves are output from our system. A hydrophone calibrated at the corresponding frequency is sufficient to measure the intensity. However, for most of the operating modes, broadband acoustic signals are involved. To measure the acoustic intensity accurately, the measuring system must be broadband calibrated. This calibration is necessary to correct for a system frequency response that is not flat when calculating intensity.

There are two ways this frequency response curve can be used to correct the measured intensity. One way is to store this curve in a computer and correct each hydrophone received signal for this frequency response in software. The second way is to build hardware that compensates the frequency response of the hydrophone so that any signal received is frequency compensated. The advantage of the first method is that it can compensate for a frequency response of any shape. The disadvantage is that it is time-consuming to carry out. Since most hydrophones have a rather simple frequency response, hardware can easily be implemented to level the frequency response to within the accuracy needed for intensity measurement.

The method used to find the frequency response of the measuring system is to repeat the sensitivity calibration at the required frequencies. This is very time-consuming to carry out based on the method previously described. However, the sensitivity calibration procedure can be modified to reduce the data collection and data reduction time significantly.

### Broadband Calibration Method

The previously described calibration methods can be simplified based on two facts. First, the constant of relative intensity profile integration,  $C_1$ , should vary only with fre-

quency, transducer aperture, and axial distance. Second, a low-frequency source transducer can be used to generate the acoustic field at the resonance frequency and at higher harmonics. The acoustic field at distance  $z$  in front of a transducer is uniquely defined by the driving frequency and aperture size. It can easily be derived that the relative intensity integral is a constant for a quartz transducer because of its frequency stability and fixed aperture. In other words, that constant should be just as stable as the radiation conductance (which is a function of electrical/mechanical energy transfer ratio). Furthermore, both constants can be predetermined and expected to remain the same for a long time. Quartz transducers can also be used to generate the sound field for calibration at the base frequency and at odd harmonics. Thus, a single transducer, appropriately selected, can be designed to carry out this broadband calibration at the required discrete frequencies. This transducer should have a lower resonance frequency so that it can cover not only the frequency range but also the frequency interval

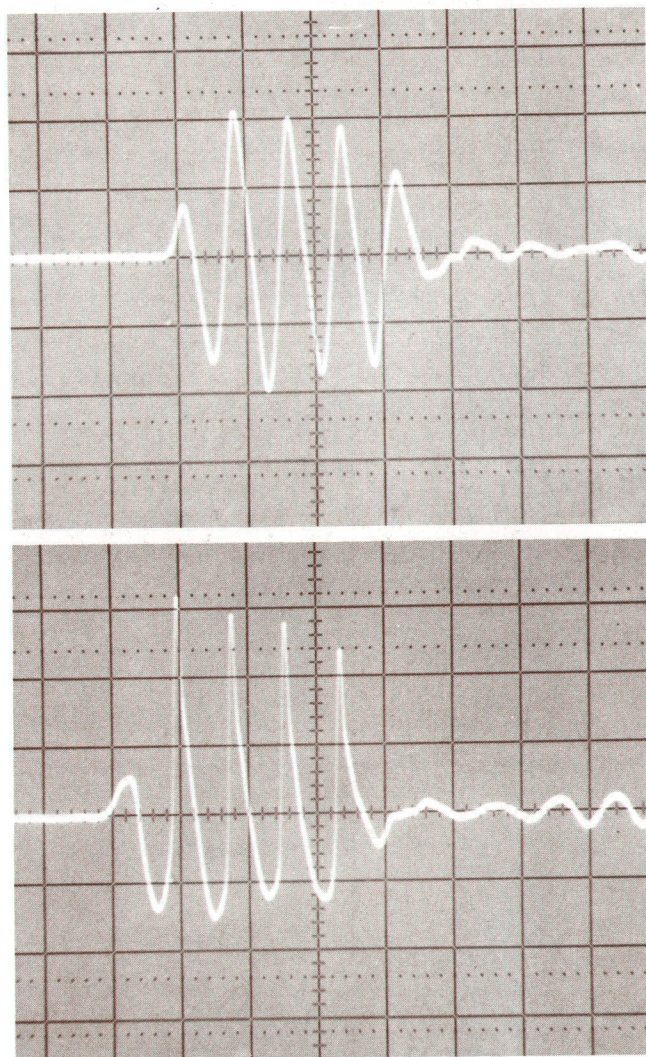

Fig. 2. Comparison of a linear waveform (upper trace) and a waveform with nonlinear distortion (lower trace). The nonlinear distorted waveform generates high-frequency spikes which affect the peak intensity significantly.

requirement. For example, a 0.5-MHz transducer can be selected to do calibration at 0.5, 1.5, 2.5 3.5, ... MHz. Sensitivity calibration is basically the same as before. However, the quartz transducer must be calibrated for its acoustic output (or mechanical conductance) at all these harmonic frequencies. Equation 3 can now be extended to this broad-band calibration case:

$$C_1(f) = \iint \frac{p^2(x,y,f)}{p^2(x_o,y_o,f)} dx dy \quad (4)$$

and 
$$p(x_o,y_o,f) = \sqrt{P_T(f)Z/C_1(f)}$$

The sensitivity coefficient becomes:

$$S(f) = \frac{v(x_o,y_o,f)}{p(x_o,y_o,f)} \quad (5)$$

### Linearity Calibration

Quartz transducers are ideal for hydrophone calibration because of their frequency accuracy and stable mechanical conductance. However, they are inefficient electrical-to-mechanical energy transformers. Thus, the hydrophone calibration is normally done at intensity levels several orders of magnitude lower than the levels put out by medical ultrasound equipment. Therefore, the linearity of the hydrophone and other measurement equipment must be calibrated to guarantee the accuracy of the intensity measurement.

This is normally carried out by comparing the hydrophone received signal with the corresponding round-trip signals when the driving transducer is driven at different intensity levels. The hydrophone is positioned at the peak pressure amplitude position beyond the end of the near field. The round-trip measurement is made when a special target is positioned at the same place. The intensity range of this calibration covers the intensity level where the hydrophone sensitivity calibration is done, and the level where intensity measurements are performed.

Another method usable for this calibration is the comparison of signals received by the hydrophone against the driving signal throughout the intensity range. In both methods it is critical to account for any nonlinear effects associated with water. Water is a medium that starts to generate nonlinear effects at rather low intensity levels, about 10 W/cm<sup>2</sup>. The way to carry out this calibration without being too sensitive to nonlinear effects is to compare the temporal average intensity instead of peak intensity. This is because nonlinearity generates high-frequency harmonics which affect peak intensity significantly. However, these harmonics are high in frequency (short time duration), so they contribute little to the time average intensity. Fig. 2 compares linear and nonlinear waveforms. Peak intensities are very sensitive to these harmonics because the high-frequency spikes occur normally at the end of the rarification phase of a pressure cycle, significantly increasing the received pressure amplitude at that phase. Since this only occurs in a fraction of the cycle of the pressure wave, the temporal average intensity is nearly unaffected

by these high-frequency spikes. All the hydrophones we have evaluated appear to behave linearly through the intensity range we normally use them for.

### Intensity Measurement

After complete calibration, the system is ready to measure intensity. This is done in a water tank where the transducer under test and the hydrophone are both immersed. Since the objective of this measurement is to measure the highest intensity the ultrasonic transducer can output, the operator has to locate a hydrophone position and a system setting that give the maximum intensity before making the intensity measurement. For an ultrasound system that uses a fixed pulse repetition rate and fixed driving voltage, the position of maximum intensity is easy to find. The hydrophone is used to search through the acoustic field for a location that gives maximum voltage amplitude.

HP's Doppler system varies its repetition rate as well as its driving voltage to meet the optimum Doppler measurement requirement. It also allows users to vary the repetition rate and driving voltage to meet their individual needs. This adds to the complexity of the search for the maximum intensity.

How we manage to determine the location of maximum intensity depends on what type of intensity is to be measured. We will limit our discussion to spatial peak temporal average intensity as an example of how intensities are measured. The spatial peak temporal average intensity  $I_{SPTA}$  is defined as follows:

$$I_{SPTA} = \frac{1}{T} \int_0^T \frac{v^2(t)}{K^2Z} dt \quad (6)$$

where  $T$  = the pulse repetition period.

To measure  $I_{SPTA}$  requires the recording of a transient waveform  $v(t)$ , and integration as shown in equation 6. The transient can be captured by a commercial transient recorder or can be captured by photographing its trace on a CRT screen and digitizing the photograph. Then software can be used to carry out the integration. Either way is a lengthy procedure and cannot easily be done in real time. In the peak intensity search phase it is very desirable to have a method that will read out  $I_{SPTA}$  instantaneously. A special instrument setup was put together for this purpose. An HP 3400 RMS Voltmeter gives an instantaneous reading of rms voltage, which can be directly related to  $I_{SPTA}$  following the simple relationship:

$$I_{SPTA} = V_{rms}^2/K^2Z \quad (7)$$

With this rms meter, the position of maximum intensity at a particular system setting can be found by moving the hydrophone in the acoustic field and reading the rms voltage output from the hydrophone. All system settings that can possibly give maximum  $I_{SPTA}$  are checked with the rms meter connected to the hydrophone. This allows us to scan along the acoustic field easily until we locate the point for maximum  $I_{SPTA}$ .

# Extraction of Blood Flow Information Using Doppler-Shifted Ultrasound

by Leslie I. Halberg and Karl E. Thiele

ULTRASOUND IMAGING in conjunction with detection of Doppler frequency shifts from the transmitted ultrasound frequency allows clinicians to measure blood flow velocity from many vessels and heart chambers in the human body. HP's Doppler instrument, the HP 77410A, is inserted functionally between the scanning and display subsystems of the HP 77020A Phased Array Medical Ultrasound Imaging System. The HP 77410A is made up of four state-of-the-art printed circuit cards and a motherboard. These cards are the Doppler detector card (DDC), the FFT (fast Fourier transform) card, the data output card, and the processor card.

## Doppler Detector Card

The HP 77410A's front end, the Doppler detector card

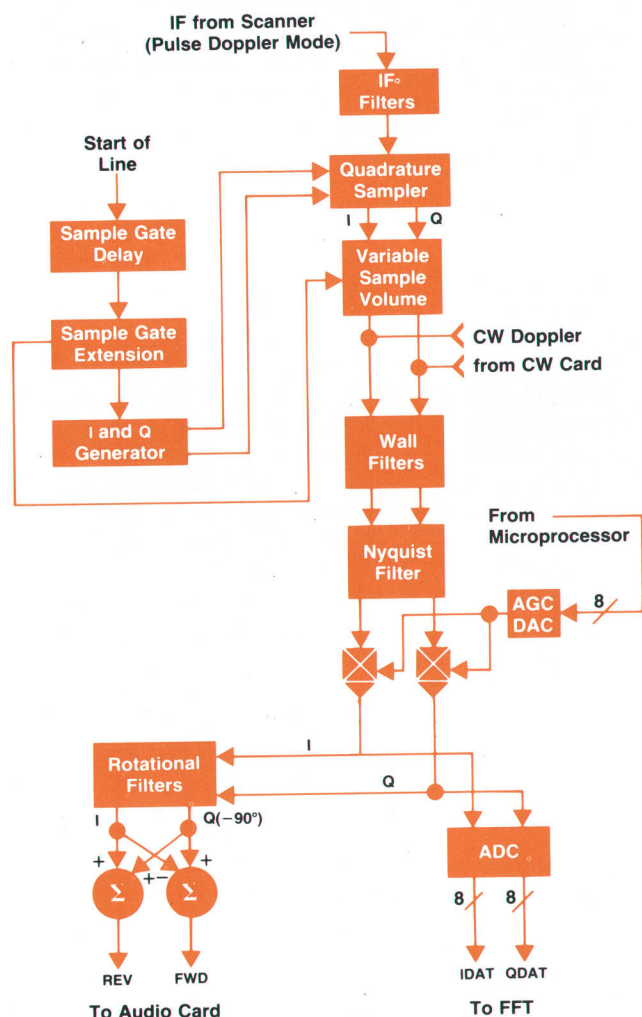

Fig. 1. Doppler detector card (DDC) block diagram.

(Fig. 1), extracts the Doppler-shifted echoes from the body. These echoes are received by one of two probes: the 64-element phased-array transducer, which for the confines of this article is used for pulse Doppler mode only, or a separate probe for continuous-wave (CW) Doppler mode. In the first case, an intermediate-frequency signal is supplied by the scanner. In the other case, a pair of baseband quadrature signals is supplied by a separate CW card. In both cases, Doppler information is extracted from the input with much signal processing to allow outputs of forward and reverse flow signals for stereo audio speakers, and a digitized complex Doppler flow signal for digital processing.

## IF Filters

The front-end filter on the DDC is referred to as the IF filter. The intermediate-frequency nature of the signal is a result of a heterodyning technique used by the scanner to steer and focus the ultrasound beam.<sup>1,2</sup> Sensitivity is critical to Doppler information extraction, which requires the front-end IF filters to be matched to the input signal. A matched filter has a frequency response equal to the frequency content of the input signal. Such a filter maximizes the ratio of peak signal power to rms noise power. This enables very low-level blood echoes to be discriminated from the noise floor of the scanner's front end.

The IF filter section (Fig. 2) consists of two parts, the first being a general filter common to all three IF signal frequencies (one for each transducer). This filter has Butterworth bandpass characteristics which pass the complete range of intermediate frequencies from one to three megahertz. In addition, a notch filter at 3.81 MHz is used to attenuate any signal component from the local oscillator for the 2.5-MHz transducer. Should such a frequency get

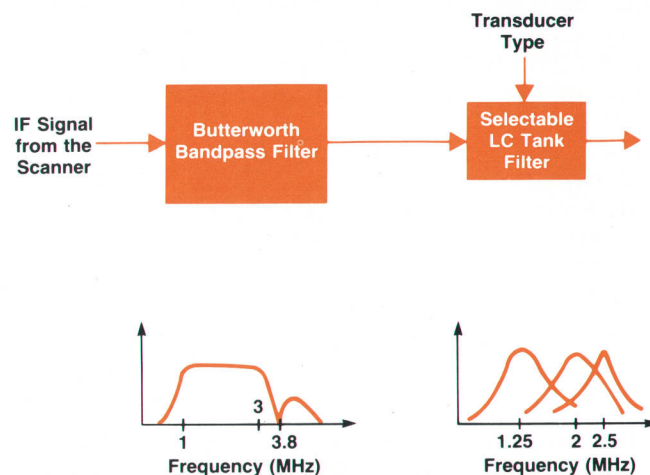

Fig. 2. IF filter section.

passed, it would result in an unwanted tone in the Doppler audio output and spectral display. The latter part of the general filter is a set of processor selectable, tuned tank circuits, one for each IF input and transducer operating frequency. Each tank circuit consists of a simple two-pole LC filter centered at 1.25, 2.0, or 2.5 MHz and having a bandwidth matched to the spectral content of the transmitted signal. Although simple in design, each tank-circuit filter (in conjunction with the Butterworth filter) provides a sensitivity within 0.5 dB of a perfect matched filter.

### Quadrature Sampler

Although the IF filters optimize the signal-to-noise ratio of the returning echo, the Doppler signal has yet to be extracted. A sampling process provides the means by which the Doppler shift is detected, and hence the means by which the blood velocity can be determined at a given depth within the body.

To describe how the sampling process works requires a basic understanding of how the desired Doppler signal is encoded in the returning echo. In pulse Doppler mode, the signal transmitted into the body, by its repetitive nature, contains energy only at the harmonics of the pulse repetition frequency (PRF). The returning echo, on the other hand, can be considered to originate from two independent types of sources. The first echo comes from stationary tissue, and like the transmitted signal, contains energy only at the PRF harmonics. The second echo originates from blood and nonstationary tissue. Since these targets are moving, the returning energy is shifted from each of the PRF harmonics by an amount proportional to the target velocity (as described by the Doppler equation). It is this shift in frequency that we detect. The sum of these two echoes is then sampled at each and every pulse repetition interval (PRI = 1/PRF) at a specific time corresponding to the depth of the desired sample volume.

One might object to the sampling of a relatively high-frequency signal (1.25 MHz) by such a slow rate as the PRF (e.g., 5 kHz), in that the Nyquist theorem is being violated. However, the theorem only refers to the ability to reconstruct the original IF signal, which is not important for pulse Doppler mode.

Looking at the signal in the frequency domain, the pro-

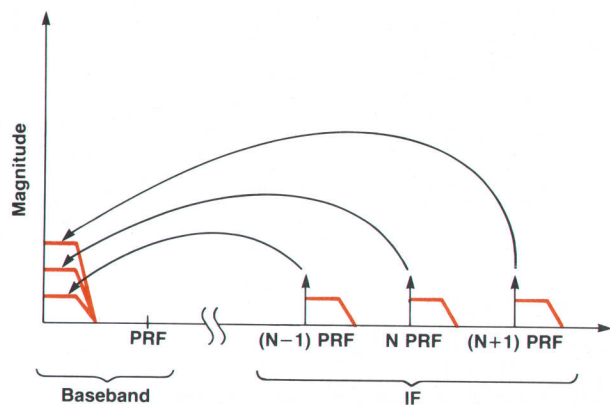

Fig. 3. Sampling the IF signal translates and sums each of the harmonics of the PRF and their respective spectrums down to baseband frequencies.

cess of ideal sampling will replicate and translate the original spectrum by integer multiples of the sample rate (i.e., the PRF). Since one is only interested in the baseband frequencies (dc to the PRF) in pulse Doppler mode, the process of sampling can be restated as the translation and summing of each of the harmonics of the PRF and their immediate spectrums down to baseband. This is shown in Fig. 3.

In ideal sampling, however, the frequency spectrum is periodic with a period of PRF Hz (see Fig. 4). This implies that the output of an ideal sampler has infinite power and energy, which is realistically impossible. In the samplers on the DDC, a zero-order hold is implemented. Once a sample is taken, the value of that sample is held for the duration of the PRI. In the frequency domain, this is mathematically equivalent to multiplying the spectral output of the ideal sampler by that of a sinc function. A sinc function is defined as:

$$\text{sinc}(x/\text{PRF}) = \sin(\pi x/\text{PRF})/(\pi x/\text{PRF}) \quad (1)$$

From Fig. 4, it can also be seen that the spectrum is mirrored about the frequency PRF/2 (this is referred to as the Nyquist rate). For a single sampler, the implications are twofold: first, the Doppler shift range can only extend from 0 Hz to the Nyquist rate, and second, positive Doppler shifts cannot be resolved from negative shifts. In other words, forward flow can not be distinguished from reverse flow when a single sampler is used. This fact is best illustrated in the time domain, as shown in Fig. 5. The echoes

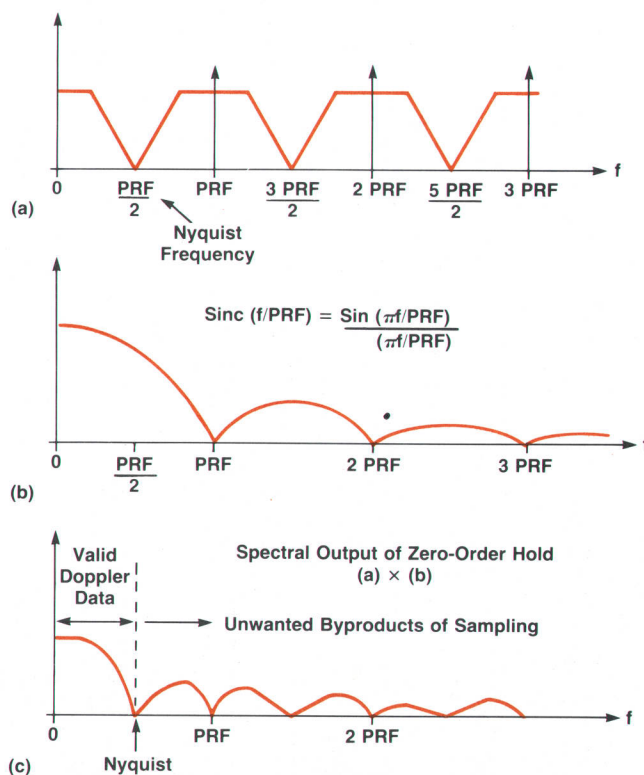

Fig. 4. (a) Spectral output of ideal sampler. (b) Sinc function. (c) Using a zero-order hold sampler has the effect of multiplying (a) by (b).

from forward-moving and reverse-moving targets are shown for five PRF intervals. The filtered output of the first sampler is the same for both directions.

Therefore, the DDC is implemented with quadrature samplers to resolve forward and reverse flow. A quadrature sampling scheme uses a second sampler (quadrature sampler) that samples a short time after the first sampler (in-phase sampler). This time delay  $\tau$  is equal to one-fourth the period of the IF. Again looking at Fig. 5, it is shown how the output signals of the quadrature sampler are different for forward and reverse flow. For forward flow, the quadrature signal leads the in-phase signal by 90 degrees, whereas for reverse flow, the quadrature signal lags the in-phase signal by the same amount. This quadrature scheme works under the critical premise that the Doppler shifts are small compared to the reference frequency, in this case the IF. We know this to be true since Doppler shifts are audible (0 to 20 kHz), whereas the reference frequencies vary from 1.2 to 2.5 MHz.

Mathematically, the filtered outputs of the two samplers can be approximated by:

$$\text{In-phase} = \cos(\omega_{\text{fwd}}t) + \cos(\omega_{\text{rev}}t) \quad (2)$$

$$\text{Quadrature} = -\sin(\omega_{\text{fwd}}t) + \sin(\omega_{\text{rev}}t) \quad (3)$$

where  $\omega_{\text{fwd}}$  and  $\omega_{\text{rev}}$  are the forward and reverse Doppler shifted frequencies.

Thus, forward and reverse flow are phase encoded in the quadrature channels. By using a decoding scheme which will be described shortly, forward and reverse flows can now be separated from one another. Equally important, by adding the second sampler, the effective Doppler bandwidth is doubled, because now Doppler shifts from  $-$  Nyquist to  $+$  Nyquist frequencies can be distinguished.

The most critical feature in the design of the samplers is the large dynamic range required (approximately 100 dB). This requires that the samplers be capable of discriminating a low-level signal in the presence of another signal one hundred thousand times larger in magnitude. This huge dynamic range places a constraint on the amount of aperture jitter the samplers can have. Aperture jitter is the variability in the actual time of sampling. A dynamic range of 100 dB leads to a tolerable aperture jitter of about four picoseconds (light travels only one millimeter in this time). To obtain this kind of performance at an acceptable cost, a discrete track-and-hold circuit was designed. The

## Continuous-Wave Doppler Board

An important part of the Doppler system is the continuous-wave (CW) Doppler board (Fig. 1). This board incorporates a 10-MHz crystal oscillator which is divided down into two 2.5-MHz quadrature clock signals. These signals, 90 degrees out of phase, each drive the high-level LO input of a mixer. One of these signals is also fed into the transmitter section of the board. The transmitter buffers the signal and sends out a 30 $\Omega$ -matched signal to the split crystal CW probe, emitting a continuous series of ultrasonic pulses. The received echo is amplified and buffered to drive the RF input of the mixers. The result of the mixing gives two quadrature baseband signals. These baseband signals are fed into

two identical bandpass filters which strip out any high-frequency components greater than 40 kHz and any low-frequency wall noise lower than 600 Hz. These filters are very carefully matched so that any phase or magnitude errors between them are kept to an absolute minimum. The two quadrature signals are then sent to the Doppler detector card which further filters them and processes them for the spectrum analysis.

*Rich Jundanian*  
Development Engineer  
Andover Division

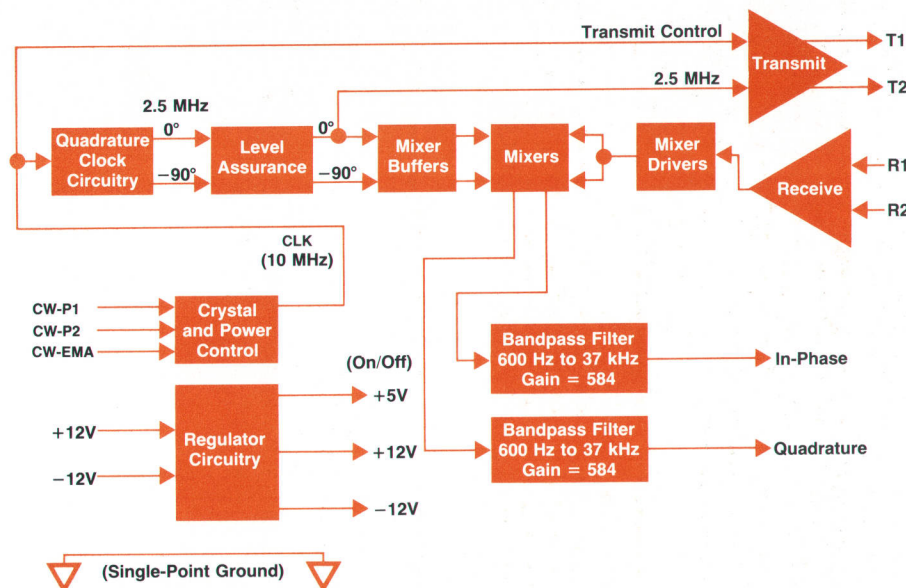

Fig. 1. Block diagram of continuous-wave (CW) Doppler board.

basis of this design is a very high-speed, low-jitter analog switch.

### Wall Filters

Of the 100-dB dynamic range of the output signal from the samplers, the upper 40-dB portion of the range consists mainly of unwanted wall signals. A wall signal refers to the echo received from stationary or slowly moving specular reflectors such as vessel walls and intervening tissue between the probe and the flow volume interrogated. Such an echo is typically 100 times as large as the echo received from blood, and is distinguished by having a low-frequency Doppler shift. Thus, a high-pass wall filter is used to attenuate these low-frequency wall signals to the point where they no longer obscure the desired blood flow data.

For a given velocity, the Doppler shift obtained from slowly moving tissue will vary according to the Doppler equation with a varying transmit frequency  $f_s$ . In addition, the velocities of slowly moving tissue can vary significantly from patient to patient. For this reason it was decided to allow a limited selection of cutoff frequencies to reject these high-level low frequencies. The wall filters on the DDC are designed with four user-selectable cutoffs: 200 Hz, 400 Hz, 600 Hz, and 800 Hz. For the 2.5-MHz transducer, 400 Hz corresponds to a target moving at 12 cm/s. By comparison, blood velocities typically exceed 100 cm/s in the aorta of a normal, healthy patient.

It is desired that these filters reject the low-frequency data without affecting the Doppler blood flow data. This is accomplished by using a filter whose characteristics provide a sharp cutoff. Since cutoff variability is a must, this implied the need for an active filter, where pole locations could be repositioned to maintain the sharp cutoff indepen-

dent of one another. A major problem in using such a filter is its nonlinear phase response in the vicinity of the cutoff. A slight variation in component tolerances between the in-phase and quadrature wall filters would induce a considerable phase difference between the two channels. Since the ability to separate flow direction depends on the phase difference between channels being exactly 90 degrees, any additional phase difference will show up as mirroring, where positive flow will be seen in the reverse flow channel, and vice versa. Therefore, the wall filters on the DDC are designed using components with tight tolerances.

### Nyquist Filter

In the quadrature channels, all the useful Doppler information is contained in the frequency band from dc to the Nyquist rate in each channel. Frequencies above the Nyquist rate are meaningless, and therefore must be removed. Thus, a low-pass Nyquist filter is needed that will pass the desired Doppler signals and attenuate the unwanted byproducts of sampling, which are shown in Fig. 4c. The biggest problem in implementing such a filter is that the Nyquist frequency is equal to half the pulse repetition rate, which is dependent on the depth of the flow being interrogated. Therefore, a low-pass filter with a variable cutoff is required.

Ideal for such an application is a highly integrated switched capacitor filter commercially available at a very nominal cost. A microprocessor-programmed clock that is phase-locked to the PRF controls the time constant of two noninverting integrators that filter the in-phase and quadrature signals from the wall filters. The relationship between the clock and the cutoff frequencies is  $f_{\text{cutoff}} = \text{PRF}/2 = f_{\text{clock}}/100$ .

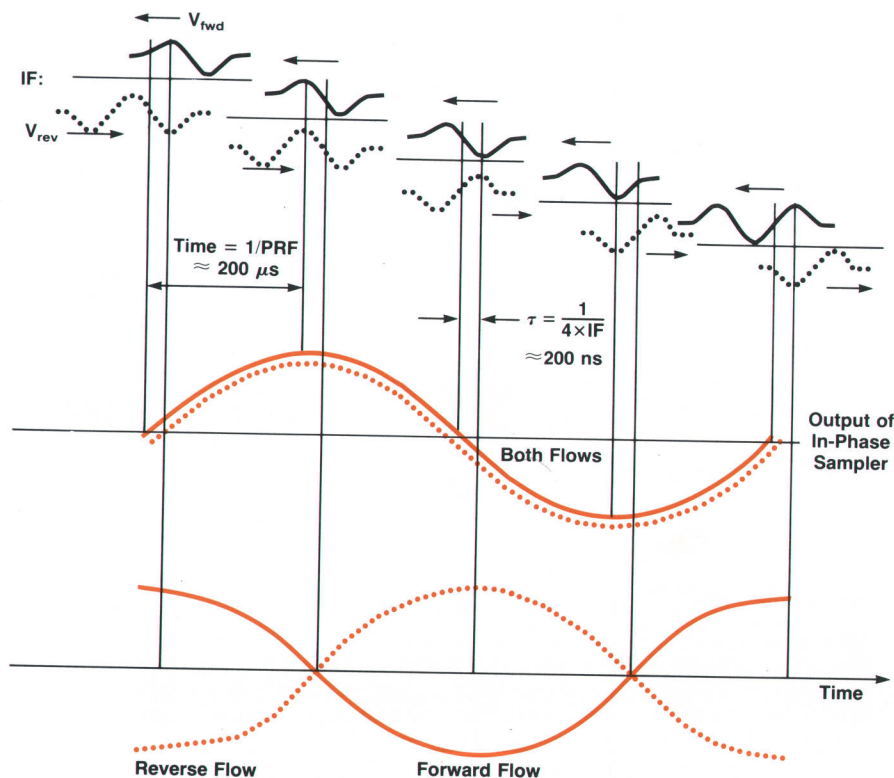

**Fig. 5.** (Top) Echoes for five PRF intervals containing both forward and reverse motion Doppler shifts. (Center) Output of single (in-phase) sampler for both echoes. (Bottom) Output of second (quadrature) sampler allows differentiation of forward and reverse flows by phase encoding.

The cutoff characteristics can be easily controlled by selecting a set of resistors whose ratio determines two pole locations. The Nyquist filter is designed as a modified Butterworth filter. Because it is a Butterworth filter, it passes frequencies from dc to the Nyquist rate with unity gain. The reason for its modification is to account for the filtering characteristics of the zero-order hold at the quadrature samplers. At the Nyquist frequency, a zero-order hold attenuates the signal by 4 dB. The modification of the Nyquist filter compensates for this attenuation by appropriately increasing the gain. Therefore, the overall DDC frequency response has an extremely flat profile from dc to the Nyquist rate. The output of the Nyquist filters is the reconstructed quadrature Doppler flow signal.

### AGC and Analog-to-Digital Conversion

After removal of unwanted signal components, it is necessary to provide gain. This gain control must be variable because the blood flow echoes extracted from different vessels and chambers vary in signal strength. This is accomplished through the use of a pair of analog multiplier chips, one each for the in-phase and quadrature channels. The gain level for these multipliers is set by an eight-bit digital-to-analog converter (DAC) under processor control, which allows for a swing of 48 dB. A complex algorithm based on the fast Fourier transform (FFT) determines when and by how much the gain should change. This algorithm also has a time constant that controls the rate at which gain is changed.

Doppler systems usually provide some sort of spectral display in which a Fourier transform is taken of the Doppler

## Observation of Blood Flow and Doppler Sample Volume

Blood flow is observed by periodically sampling the ultrasonic backscattering from blood moving through a selected region. The results are processed to obtain blood velocities. The term velocities is appropriate since the sample contains cells moving at varying and various speeds and directions throughout the sample volume.

The angular location of the sample is selected by directing the transducer. The lateral size of the sample depends on aperture and focus. Pulsed Doppler techniques permit selection of the sample site and extent. Larger sample sizes make searches easier; smaller sample volumes permit pinpointing of flow phenomena. The Doppler data is usually obtained and displayed together with the image.

Pulsed Doppler mode creates a sample volume in the following manner. A burst of several pulses is launched periodically. The return from scatterers in the blood is sampled some time later

with the same periodicity. The delay time determines the axial location of the sample volume and the length of the sample volume depends on the duration of the burst. It should be noted that signals returned from cells throughout the entire volume arrive at essentially the same instant so that the electrical sample represents the sum of all scattering within that space. The first pulse launched travels farthest and the pulse launched last travels the shortest distance, but their reflections arrive together (see Fig. 1).

Extension of the sample volume can be obtained by an increase in the transmitted burst length, but we have chosen an alternative method where the volume is extended by accumulating additional samples taken at appropriate successive intervals. The effect is to increase the volume as desired without having to change the transmitted burst in any way (see Fig. 2).

If the burst length is reduced to a single pulse and the period between bursts is reduced to the pulse period (the ultrasound period), the arrangement becomes a CW Doppler system. The sample length then extends indefinitely. This has the effect of a searchlight which affords a fast, deep look, but has no spatial resolution. In this mode, the transmitted amplitude is reduced to maintain an allowable power level.

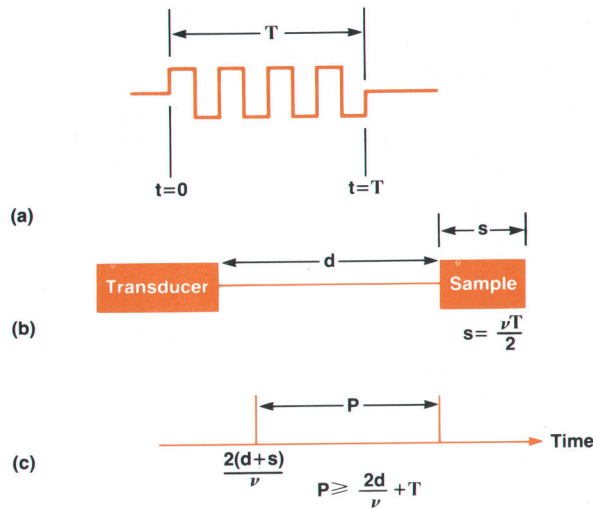

**Fig. 1.** The leading edge ( $t=0$ ) of the pulse train (a) returns from the far end of the sample volume (b) at time  $2(d+s)/v$ . The trailing edge ( $t= T$ ) of the pulse train returns from the near end of the sample volume at time  $T + 2d/v$ . For  $s = vT/2$ , these returns are simultaneous and therefore are automatically summed by the sampler. (c) The sampling period  $P$  is at least equal to  $T + 2d/v$ .

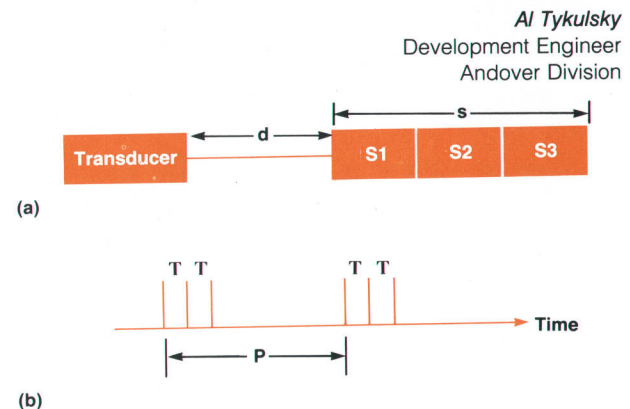

**Fig. 2.** To extend the sample volume (a), the sampler operates a number of times (b) at intervals of  $T$  for each sampling period. The results are accumulated.

AI Tykulsky  
Development Engineer  
Andover Division

signal. In HP's system, this is performed by an FFT algorithm, which requires the DDC to digitize the Doppler signal. At first glance, it would seem reasonable to digitize the forward/reverse flow information coming out of the rotational filter, and perform separate Fourier transforms on each signal. However, the rotational filter has nominal phase errors of up to two degrees, which will induce some mirroring on the spectral display, although it has little effect on the degree of stereo separation in the audio output. Therefore, it was decided to digitize the Doppler data before separating the forward and reverse components, and to allow a single complex FFT to perform this requirement. Two eight-bit SAR-type analog-to-digital converters (ADCs) digitize the in-phase and quadrature outputs of the multipliers and send the data to the FFT card.

### Flow Direction Decoding

Each of the in-phase and quadrature signals contains the Doppler information for both forward and reverse flow. Each by itself is incapable of differentiating the direction of flow, but considered together, the two signals allow flow direction to be determined.

The rotational filter accepts as inputs the in-phase and quadrature signals from the multipliers, decodes the signals, and outputs forward and reverse flow values. The first step consists of delaying the quadrature signal by 90 degrees relative to the in-phase signal. These new signals, in-phase and quadrature ( $-90^\circ$ ), are such that the forward flow information is in phase ( $0^\circ$  phase difference) for the two channels and the reverse flow information is 180 degrees out of phase. When the two channels are summed, the forward flow values add, whereas reverse flow data is canceled. On the other hand, by taking the difference of the two channels, forward flow is eliminated, and only reverse flow is left.

Mathematically this can be seen by referring to the equa-

tions for the outputs of the quadrature sampler (equations 2 and 3). Rewriting equations 2 and 3 to account for the 90-degree phase delay,

$$Q(-90^\circ) = \cos(\omega_{\text{fwd}}t) - \cos(\omega_{\text{rev}}t) \quad (4)$$

Taking the sum and difference of equations 2 and 4:

$$\text{Sum} = I + Q(-90^\circ) = 2 \cos(\omega_{\text{fwd}}t) \quad (5)$$

$$\text{Difference} = I - Q(-90^\circ) = 2 \cos(\omega_{\text{rev}}t) \quad (6)$$

Thus, the sum channel contains the forward flow and the difference channel contains reverse flow. These signals are then sent to an audio driver card which drives a set of stereo speakers on the sides of the ultrasound system cart, and also an optional headset.

The biggest design challenge in implementing this rotational filter was how to delay the Q channel by 90 degrees over a relatively large frequency range (200 to 20,000 Hz). This suggested the need for an all-pass filter, or phase shifter, which adds phase to the signal while passing all frequencies. Since it is extremely difficult to shift a single channel by an absolute 90 degrees, the rotational filter actually phase delays both in-phase and quadrature signals, such that the phase difference between the two channels is 90 degrees over the desired frequency range.

The operation of the FFT card for the spectral display is described in the article on page 45.

### References

1. R.N. McKnight, "A Mixing Scheme to Focus a Transducer Array Dynamically," *Hewlett-Packard Journal*, Vol. 34, no. 12, December 1983, pp. 16-17.
2. R.D. Gatzke, J.T. Fearnside, and S.M. Karp, "Electronic Scanner for a Phased-Array Ultrasound Transducer," *ibid*, pp. 13-20.



# Modifying an Ultrasound Imaging Scanner for Doppler Measurements

by Sydney M. Karp

**T**HE HP 77200B SCANNER is the beam forming electronics box in the HP 77020A Phased Array Medical Ultrasound Imaging System. To understand how beam forming is done, consider the hypothetical phased array system shown in Fig. 1. This system consists of  $n$  parallel channels, each with its own transmitter and receiver. Each transmitter outputs an ultrasound pulse of short duration into the human body. The pulse is partially reflected by structures in the body and these reflections are detected by the receivers. The receivers then send the resulting signal to a delay mechanism and a summing junction.

By appropriate choices of delay settings, beam steering can be performed. If the transmit delays are set so that the delay for element  $i$  is equal to  $(i-1)T$ , then an acoustic wave is launched from element 1 at time 0, followed by a wave from element 2 at time  $T$ , and so on. Referring to Fig. 2a, these waves add to form a composite plane wave traveling in a direction at an angle to the normal of the array. By varying  $T$ , the direction of the beam can be changed. The composite wave can be formed into a nonplanar wave by choosing a nonlinear sequence of delays. An appropriate sequence of delays can result in a curved wave front that converges (is focused) at a single point, as shown in Fig. 2b.

Reception of a wave operates in a reverse manner. Reflections from a target are returned to the transducer elements as curved wave fronts similar to those shown in Fig. 2b. The response of each element is amplified, delayed, and added to other element responses by a summing junction (see Fig. 1). Constructive addition of the element responses occurs when the delays are selected to compensate for the fact that a single wavefront strikes different elements at different times. As the incident waves are reflected from targets deeper in the body, their radius of curvature increases. It is possible to track this change in curvature by dynamically altering the delay settings during reception. This feature, known as dynamic receive focusing, provides an extended depth of field.

## Architecture

A block diagram of the scanner is shown in Fig. 3. A custom HP MC-5 microprocessor determines the scan mode by programming various cards in the system. The timer provides the timing and clock signals needed to transmit pulses and receive reflections at the desired time for each line. Transmitter and receiver time delays, or coefficients, are sent over the coefficient bus by the coefficient generator card.

Transmitter time delays are produced by counters programmed by the coefficients. The outputs of these counters are stepped up to form the high-voltage pulses required to drive the transducer array. Echoes are detected by the same array and passed on to the receiver processing chain. Receiver delays are achieved by two different mechanisms, both programmed by coefficients. Fine delay adjustment is produced by altering the phase of the mixing frequency used to convert the received RF signal to the desired IF. The receiver outputs are then entered into appropriate taps of a summing delay line. The choice of a tap input corresponds to a coarse receive delay. The output of the tapped delay line is summed IF, ready for processing by the Doppler instrument. Receiver gain is modified by the time gain compensation (TGC) generators. The generator outputs increase receiver gain as a function of time to compensate for the weaker echoes received from deeper in the body.

The HP 77200A Scanner underwent considerable changes to allow acquisition of Doppler data, and to interface to the Doppler instrument (HP 77410A). Major changes were made to the processor, timer, coefficient generator, and TGC functions. The operating software was restructured with the help of new hardware capabilities. A description of the scanner problems and solutions involved in achieving a Doppler capability is given in this article. For a more detailed description of the operation of the rest of the imaging system, see references 1 and 2.

## Scanner System Interface

Commands defining the modes of operation are received

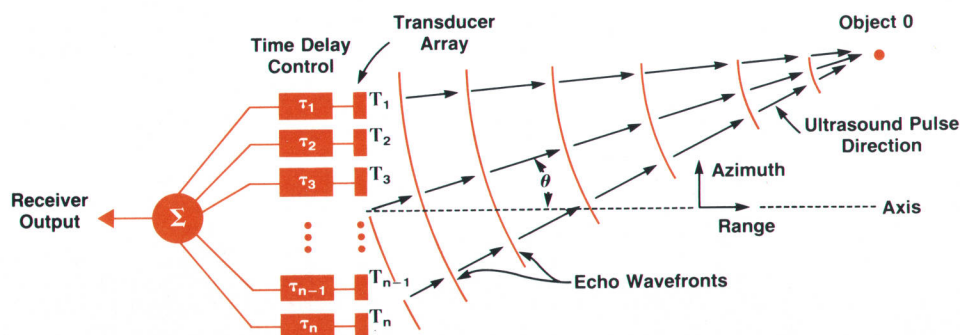

Fig. 1. Block diagram of basic phased-array ultrasound imaging system.

by the scanner processor from the HP 77120A Controller Subsystem over an HP-IB (IEEE 488/IEC 625) link. Image data is digitized in the scanner and passed through the HP 77410A to the HP 77400B Display Subsystem (DSS). There, it can be postprocessed and displayed on the monitor.

Doppler echoes are received by the scanner at an RF frequency of 2.5, 3.5, or 5.0 MHz, depending on the transducer used. These frequencies are mixed down to 1.3, 1.9, and 2.5 MHz, respectively, and tapped off the scanner's video processor card to be sent to the Doppler subsystem. The scanner timer generates a 60-MHz master clock and start-of-line sync pulse for the HP 77410A. This clock is used to phase-lock the HP 77410A's sampling of the IF signal to the scanner.

### Dynamic Coefficient Generation

The most significant feature incorporated into the new scanner is the dynamic calculation of delay coefficients. The coefficients determine the angle and depth of focus of the acoustic beam for both transmit and receive. This is accomplished by adjusting the time delays of transmitted pulses and detected echoes. Earlier versions of the coefficient memory card stored the coefficients in a large set of EPROMs (electrically programmed read-only memories). This limited amount of read-only memory allowed the scanner to support only four different transducers. Instead of storing a set of coefficients with fixed foci, dynamic generation of coefficients allows focusing at any point in the scan sector, a major requirement for Doppler operation.

For each acoustic beam angle, a set of transmitter, tap selector, and mixer coefficients was originally stored. Additional sets of mixer coefficients allowed fine adjustments of focusing while receiving, providing the dynamic focusing capability of the instrument. Thus, the receive focusing consisted of several radial focal zones, while the transmit focus was fixed at one depth.

For accurate extraction of Doppler-shift information, it is desirable to calculate a set of mixer coefficients to focus the beam precisely at the sample volume. This can give improved signal-to-noise ratios, since Doppler operation then does not rely on the approximate focusing of a mixer focal zone. As the operator moves the Doppler sample gate around the sector, searching for blood flow, the scanner dynamically recalculates transmit and receive Doppler coefficients to focus the beam at the sample gate location precisely. This was accomplished by replacing the coeffi-

cient EPROMs with a 68000 microprocessor and a RAM.

When a new transducer is installed, the processor board recognizes this change and the MC-5 microprocessor communicates the transducer identity to the 68000. New coefficients for a full sector are calculated, requiring about three seconds. Since coefficients are stored for only one transducer at any one time, the RAM memory space needed is much smaller than the earlier EPROM space. Transmit coefficients for four different imaging depths are calculated and stored. This allows the optimal transmit coefficients to be selected dynamically each time the sector depth is changed, without any coefficient recalculation.

When Doppler mode is enabled, the coefficients for a single Doppler line are calculated, focused at the sample gate. Each time the sample gate is moved by the operator, commands are received by the scanner describing the new gate position. Then the coefficients for the Doppler line are recalculated. Since only one line and one focal zone are involved, the recalculation takes only 15 ms.

### Timer Changes

The second major hardware change to the new scanner involved synchronizing all clocks in the instrument. Earlier scanners had separate crystal oscillators driving the transmitters, mixers, video analog-to-digital converter (ADC), and microprocessor hardware. Doppler operation requires that all these processes be synchronized, otherwise different phase relationships at successive Doppler sample times will create phase changes in the Doppler data. This would manifest itself as erroneous Doppler flow signals.

The timer card was chosen to be the source of all scanner clocks. Master frequencies of 120 MHz or 180 MHz can be generated on this card, depending on transducer frequency. These master frequencies were chosen so they could be divided down to the mixer and transmitter frequencies required by the different transducers. The video ADC clock and all other clocks are also derived from the master clock.

New Doppler modes involve sequences of both imaging and Doppler lines. In duplex Doppler mode, the scanner alternates between firing imaging and Doppler lines. This allows the generation of an imaging sector and Doppler outputs simultaneously. Thus the position of the Doppler sample volume within the body can be easily determined. The disadvantage is that the Doppler sample rate is fairly low, about 2 kHz. This limits the maximum resolvable flow velocity.

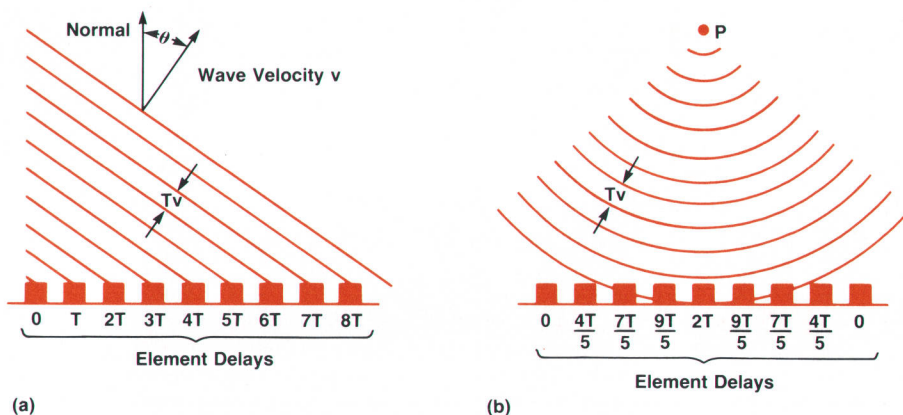

**Fig. 2.** (a) Phased array radiating a plane wave at an angle  $\theta$ . (b) By proper selection of the delay for each transmitting element, a curved wavefront can be generated that is convergent on a desired location P.

In Doppler only mode, the image is first frozen, and all lines are then devoted to Doppler shift detection. Doppler sample rates are as high as acoustic limitations allow. Each Doppler line can be terminated as soon as the transmit pulse has propagated to the sample volume and been reflected back to the transducer. This allows the determination of higher flow velocities than possible using duplex mode. In triggered Doppler mode, the scanner fires only Doppler lines until a trigger is received at a selected point on the associated ECG trace. The scanner then interrupts the Doppler outputs to update the frozen image sector. This mode gives the user a compromise combination of position determination with high-velocity flow resolvability.

Doppler lines have different timing requirements from image lines. If the Doppler gate is set for a shallow location, the Doppler line will be shorter than the image line. Doppler lines do not require the timer to initiate new mixer focal zones for dynamic focusing. Duplex Doppler mode involves alternating between Doppler and image lines. Since reprogramming the timer after each line would be prohibitive, a dual timer was designed. The individual counters that generated timing signals have been removed and replaced with a large RAM. A master counter sequentially reads the contents of each RAM location. The RAM outputs are used as timing signals. Appropriately programming the RAM makes timing signals appear when needed. The RAM contains two pages, one for image lines, and one for Doppler. The page address can be toggled easily and quickly between lines.

### Processor Enhancements

A number of other hardware changes supported the re-vamping of the software. While scanning, the main task of the MC-5 microprocessor is to assemble control bits and a line number for the next acoustic line to be fired. The processor must also monitor the HP 77020A Imaging System's internal bus based on the HP-IB for new commands, and take care of housekeeping background tasks. This overhead was previously performed between sector frames.

Doppler mode requires the highest possible line rates to detect high blood flow velocities without aliasing. Large software overhead times added to the acoustic line time could not be allowed. In addition, the Doppler sample rate cannot tolerate any interruptions for overhead processing between frames.

To make the most efficient use of the time available, and to ensure that enough time is put aside for line control bit generation, a priority interrupt scheme is implemented. The highest-level interrupt is programmed to be generated by the timer card. This interrupt directs the MC-5 processor to assemble the control bits for the next line. The remaining time for each acoustic line is available for background processing. Lower-level interrupts can interrupt the background processing to service a new HP-IB command or to respond to the 68000 coefficient processor.

In earlier scanners a great deal of processing time was spent determining the next line type in a sequence. Sector, Doppler, and M-mode line types need to be fired in different sequences depending on parameters such as sector size or nonimaging modes being enabled. Once the line type was determined, its line number and control bits had to be found. Sector line numbers had to be counted as scanning proceeded across the sector.

To reduce the processing time during scanning, a large RAM line table is added to the processor card. Before scanning, the software fills this table in accordance with the mode selected. The table contains an entire frame of entries. Each entry contains bits to determine the line type, the line number to be fired, and all the control bits necessary for that line. Once scanning begins, the software need only read each table entry, perform a few tests, and load the control words into a control register. Upon a mode change, the entries in the line table are recalculated.

### Power-Limiting Software

The addition of Doppler capabilities to the HP 77020A Imaging System intensified the need to limit the transducer's acoustic power output by carefully controlling its

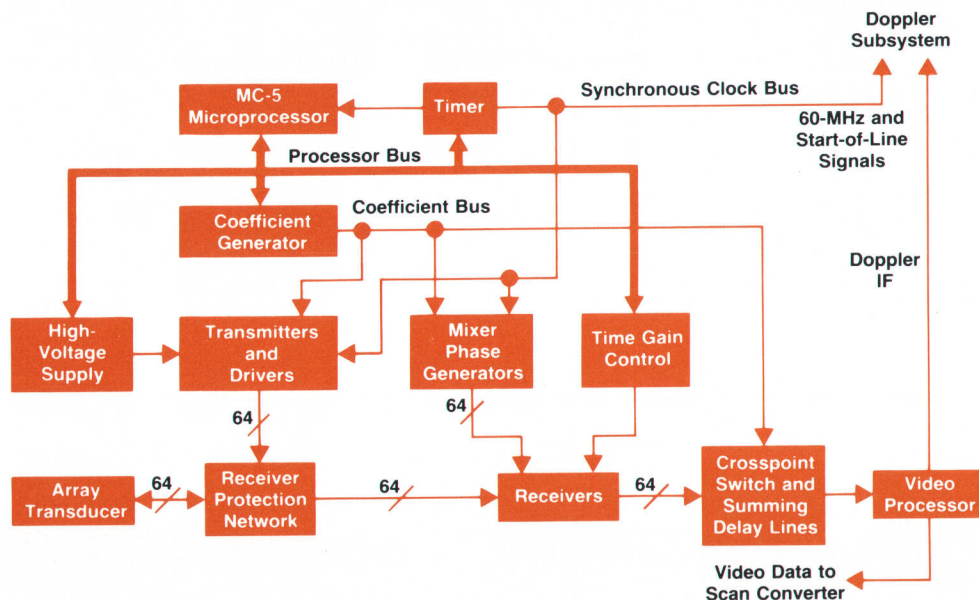

Fig. 3. Block diagram of ultrasound imaging scanner with Doppler mode.

drive voltage. Firing lines at high repetition rates through the singular angle of the Doppler sample volume greatly increases the spatial peak power averaged over time ( $I_{SPTA}$ ).<sup>3</sup> Software was developed to limit the output power to clinically acceptable levels. A register is added to the power supply card to scale all transmitter settings as necessary. Software calculates the maximum possible  $I_{SPTA}$  by examining the scan sequence. The number of pulses fired through the sample volume is divided by the period of the entire sequence. The transducer acoustic efficiency and focal quality are also factored in. Focal quality is a function of depth, depending on where the elevation focus is fixed by the lens of the probe. Once the maximum  $I_{SPTA}$  is calculated, it is scaled down to clinically acceptable levels by programming a reduced transmit drive voltage. (Refer to the article on page 31 for a discussion of how acoustic power is measured.)

### Transmit and TGC Controls

To make system operation as simple as possible, it is desirable to eliminate the need for the operator to make gain control changes when scanning modes change. Typically, the operator first optimizes the control settings with only imaging mode on. Imaging usually requires moderate to high levels of transmit power and moderate TGC receiver gain settings. Thus, the full dynamic range of the front end is rarely used in imaging. Higher TGC settings cause the image to bloom and become noisy.

Echoes received from body tissue typically are 40 dB higher than those from blood. Therefore, the optimal system configuration for imaging does not usually coincide with optimal Doppler operation. Increasing transmit or TGC gain to allow for good Doppler data would degrade

the sector image unacceptably. Too large a Doppler signal could cause saturation, producing unwanted tones in the audio and spectral display outputs. Thus the Doppler signal requires a greater dynamic range. To resolve the differing sensitivities, a separate three-position Doppler transmit control was added. One position yields the maximum clinically acceptable output power. The other two positions scale transmitted power down by 3 and 7 dB.

To resolve TGC-related issues, registers are added to the TGC card to offset the TGC gain selected by the operator automatically. Separate registers are included for imaging and Doppler offsets. The Doppler offset is always set higher by the software to allow Doppler mode to use all of the front end's dynamic range. Whenever a new transmit maximum is set as a result of a mode change, the TGC offsets are modified to compensate for any changes in transmit gain. Hence, the round trip gain remains the same and the image maintains its current intensity. Thus, optimized images do not change when control modifications are made.

### Acknowledgments

Many people contributed to the development of the HP 77200B Scanner. Paul Hempstead designed the interrupt driven scanner software. Tom Hunt, Jacques Desjardins, and Jim Mniece designed the coefficient memory, TGC, and timer cards, respectively. Ron Gatzke was responsible for project management of the scanner development.

### References

1. *Hewlett-Packard Journal*, December 1983, pp. 3-28.
2. *Hewlett-Packard Journal*, October 1983, entire issue.
3. T.L. Szabo and G.A. Seavey, "Radiated Power Characteristics of Diagnostic Ultrasound Transducers," *ibid*, pp. 26-29.

# Digital Processing Chain for a Doppler Ultrasound Subsystem

by Barry F. Hunt, Steven C. Leavitt, and David C. Hempstead

**T**HE DIGITAL PORTION of the Doppler processing chain (see article on page 35) in the HP 77410A Doppler System is composed of several large functional blocks: a fast Fourier transform (FFT) circuit, moment calculators, digital filtering, and waveform software. These blocks serve to complete the transformation of the raw time-domain quadrature samples supplied by the detector into a gray-scale spectral frequency presentation (time on the X axis, frequency on the Y axis, and magnitude on the Z axis), and spectral mean, maximum, and standard deviation waveforms.

The FFT performs the transformation from the time domain to the frequency domain. It takes 128 eight-bit quadrature samples obtained from the depth of interest, and yields a 12-bit complex 128-point spectrum. Because the input data rate is slow with respect to the required update rate for display of the spectrum (typical sample rates are about 5 kHz, while a new spectrum is required every millisecond), an input buffer is used to decouple the FFT processing from the sampling process. This allows a new spectrum to be calculated on demand, regardless of how many new input samples have been taken. In fact, most of the samples in the input buffer will overlap with previous FFTs. This overlap serves to smooth the gray-scale spectral

presentation, a desirable function. A quick calculation shows that for a 5-kHz sample rate, only five new samples are taken in the one millisecond that elapses between spectral updates. This overlap also improves the waveform displays by providing some continuity between consecutive mean, maximum, and standard deviation estimates.

Fig. 1 illustrates what a spectral display looks like with Doppler information waveforms present (in this case, the spectral mean and maximum are displayed). Fig. 2 shows the functional block diagram for the digital signal processing of the complex time-domain Doppler data.

The FFT is designed around a 12-bit flash multiplier chip. This device is capable of performing a  $12 \times 12$  multiply (yielding a 24-bit product) in 140 ns. A 128-point radix-2 FFT requires 448 butterflies (which in turn, become  $448 \times 4$  or 1792 integer multiplies) performed in seven passes of 64 butterflies each. (The operation for processing two points internal to an FFT is referred to as a butterfly since the signal flow graph resembles one.<sup>1</sup>) Since the FFT structure is internally summing two numbers on each pass, one would expect a seven-bit growth from a seven-pass FFT. Thus, since we start with eight-bit samples and have seven passes, one would expect these sums to grow to  $8 + 7$ ,

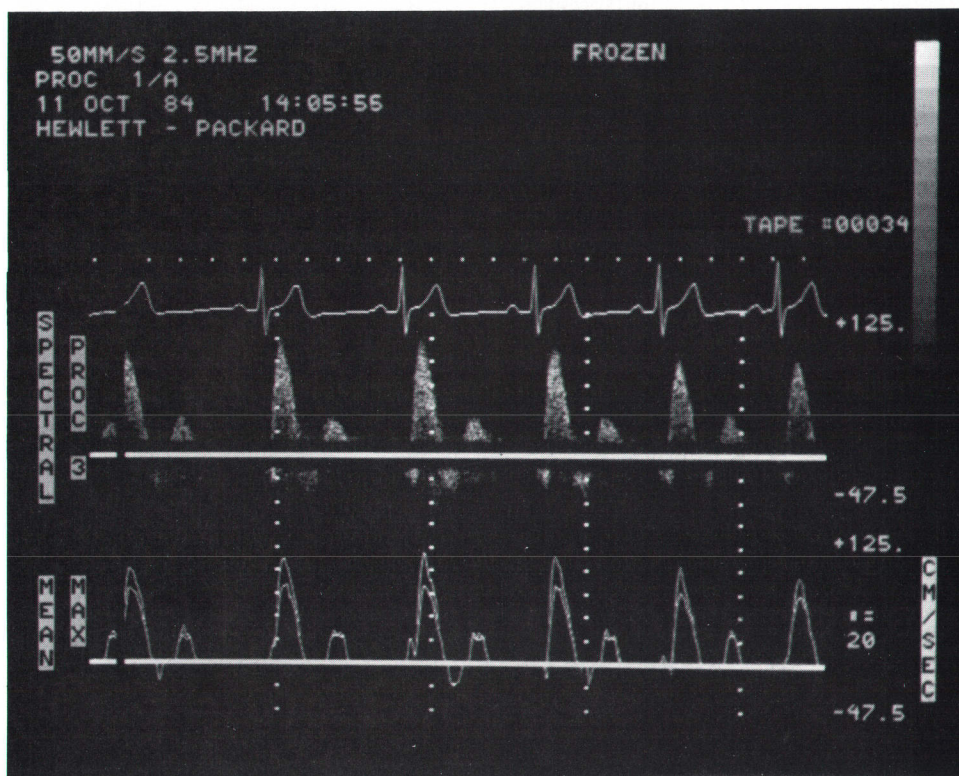

**Fig. 1.** Spectral display with Doppler information waveforms present.

or 15 bits of significance. This does occur. Carrying only 12 bits internally means, then, that overflows can potentially occur during the final three passes. Fortunately, these overflows can be minimized by decreasing the front-end input gain. Overflows are less likely to occur with broadband input signals in the presence of noise (a realistic Doppler scenario). Pure tones would be more likely to cause overflows in any one frequency bin.

At the completion of each FFT, the spectral results are transferred to the waveform moment calculators. This operation is accomplished by effectively adding an eighth and ninth pass to the FFT operation. This time is also used to transfer the input buffer's data into the FFT working memory for the next transform. Thus, we can determine the total FFT calculation time by multiplying the nine passes by the 64 butterflies per pass and by the eight 5-MHz (system master) clocks necessary per butterfly. The resulting total time is 907  $\mu$ s.

### Spectral Moment Calculations

After the FFT operation, a good amount of number crunching still remains. The first block of circuitry converts the complex spectrum into magnitudes by squaring, summing, and taking the square roots of the real and imaginary components for each of the 128 spectral bins. Again, this process must be run at the 907- $\mu$ s rate to be ready for the next FFT output.

After magnitude conversion, the data is passed through a ROM that contains several spectral compression maps,

ranging from linear to logarithmic. These maps are selected by the user, depending on what information is sought from the spectrum.

Once the magnitude of each of the 128 bins is computed, the spectral mean, maximum, and standard deviation need to be determined. This calculation also must be performed in the same time (i.e., one FFT time, or 907  $\mu$ s). To compute the mean frequency of a spectrum, several summations take place. The statistical names of these sums are the zeroth moment and the first moment. The zeroth moment is simply the sum of the 128 bin magnitudes. The first moment is the sum of the 128 bin magnitudes multiplied by their corresponding bin number. The mean, then, is defined as the first moment divided by the zeroth moment. To determine the standard deviation, a third summation, the second moment, is computed. The second moment is merely the sum of the 128 bin magnitudes multiplied by the square of their corresponding bin numbers. The standard deviation is defined to be the square root of the second moment divided by the zeroth moment, minus the mean squared. The equations are:

$$\text{Zeroth moment} = \sum_{\text{bin}=0}^{127} \text{Magnitude (bin)}$$

$$\text{First moment} = \sum_{\text{bin}=0}^{127} \text{Magnitude (bin)} \times \text{bin}$$

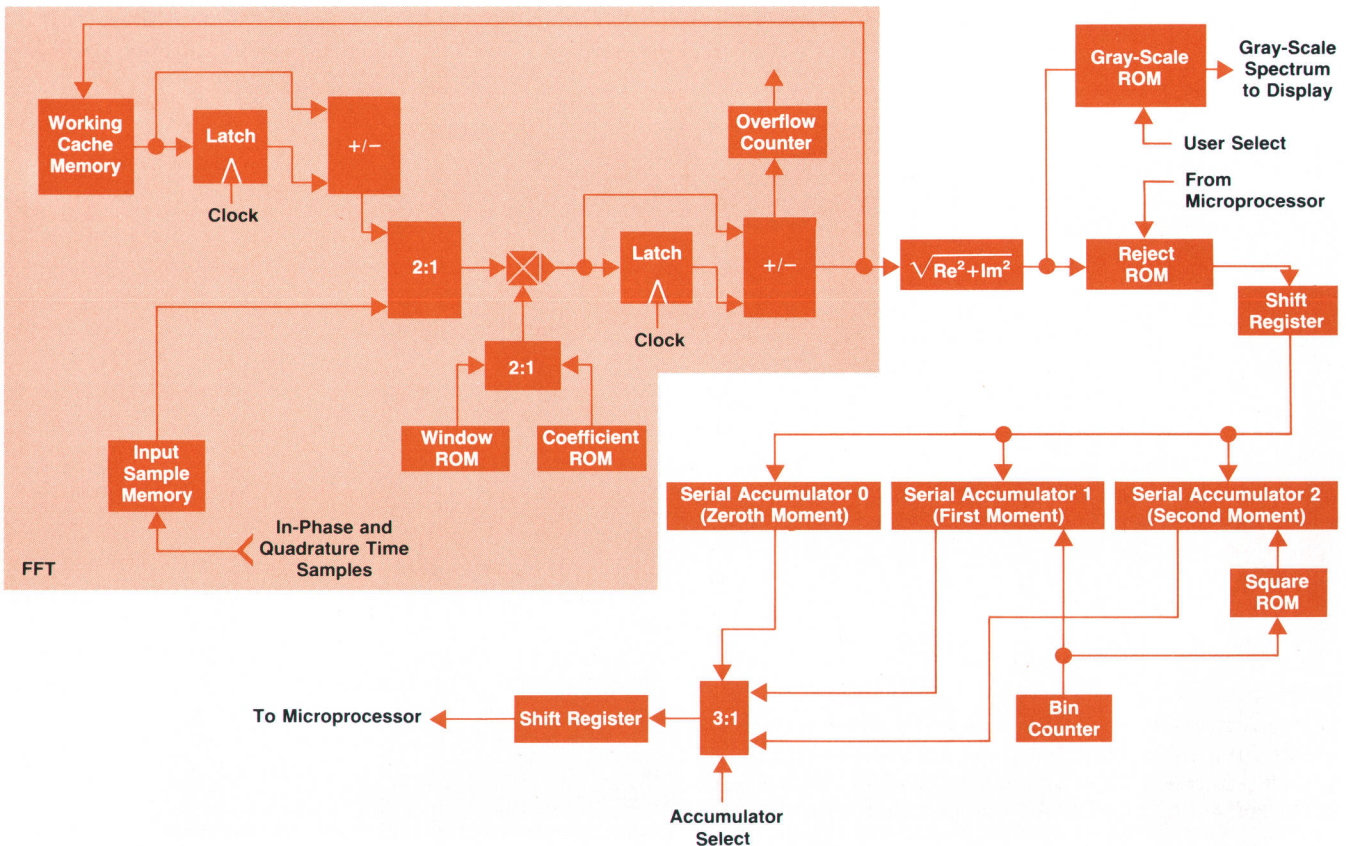

Fig. 2. Block diagram of digital processing chain.

$$\text{Second moment} = \sum_{\text{bin}=0}^{127} [\text{Magnitude}(\text{bin}) \times \text{bin} \times \text{bin}]$$

$$\text{Mean} = \frac{\text{First moment}}{\text{Zeroth moment}}$$

$$\text{Standard deviation} = \sqrt{\frac{\text{Second moment}}{\text{Zeroth moment}} - (\text{Mean})^2}$$

These moment calculations require 256 multiplies, 128 squaring operations, and  $3 \times 128$  or 384 additions. Also, the growth of the summations is a problem. The magnitudes of each bin are stored at this juncture as eight-bit quantities. In the first moment calculation, if we multiply an eight-bit quantity by a seven-bit bin number, we get a 15-bit product. Summing over 128 bins yields a 22-bit result. The second moment is potentially worse, since we multiply by a squared quantity (seven bits squared gives 14 bits). The second moment could then grow to 29 bits. To resolve the long word lengths and to avoid using another flash multiplier in a time-shared fashion, serial calculations are used. By serializing the data paths and using a hybrid serial multiplier (half serial, half parallel), the amount of circuitry needed is greatly reduced. This works because we have  $907 \mu\text{s}$  to complete each summation. We can calculate the maximum number of bits we can work with in a serial fashion by dividing the time available in clocks by the number of multiplies (or additions, since they are done serially as well). That number comes out to be  $4550 \div 128$ , or 35 bits. Since our largest moment grows to only 29 bits, we have sufficient time for performing all moment calculations in a serial fashion.

### Frequency-to-Velocity Conversion

Once the hardware completes calculating the moments, the processor is interrupted. In response to this interrupt, the moment accumulators are read along with the 128 bins of spectral data. The reason for this hardware/software combination is twofold. First, there is the requirement for a 29-bit-by-15-bit divide. While this process can be implemented in hardware, a software implementation is preferred because of its lower cost. Second, since we need only two divides for each mean/variance pair, there is sufficient time available.

The mean calculation simply requires a single division, while the standard deviation needs one division, one multiplication, a subtraction, and a square root. The numbers used in these calculations range in size from 15 bits (for the zeroth moment) up through 29 bits (for the second moment). The calculation of the mode takes somewhat longer in software. All 128 bins of spectral data must be checked for maximum amplitude and a simple bin-to-bin averaging scheme is used to minimize the effect of noise spikes. Sometimes, an estimate of the maximum velocity present is needed. This calculation puts the heaviest load on the software. To calculate a maximum velocity, the software must search through the 128 spectral bins and attempt to determine the noise floor of the data. Then the software again searches through all 128 bins, this time looking for

the maximum frequency bin containing an amplitude well above the noise floor.

After completing the statistical computations, a smoothing low-pass filter is used to eliminate noise spikes in the output waveforms. As a final step, the digital values for mean, variance, mode, or maximum are written to 10-bit digital-to-analog converters (DACs).

The analog waveforms output by the DACs represent the mean frequency and standard deviation of the Doppler spectrum. They are mapped to the mean and standard deviation of the blood flow velocities through the Doppler relationship:

$$\text{velocity} = \Delta f C / (2f_s \cos \theta)$$

where  $f_s$  is the frequency of the acoustic energy,  $C$  is the velocity of sound in the body, and the variables  $\Delta f$  and  $\theta$  are calculated by the microprocessor from the pulse repetition frequency (sample rate) and the direction of the angle cursor on the sector. The angle cursor is a special user-manipulated orientation graphic superimposed on top of the two-dimensional display image. The clinician points this cursor in the direction of expected flow, and all velocity numbers are corrected by this flow angle cosine term.

These corrected velocity numbers are very useful for determining the volume of blood flowing in a vessel at a particular interval during the heart cycle, and provide some measure of turbulence. In addition, the peak velocity can give some indication of the amount of occlusion in a vessel, since the narrower an opening, the higher the velocity of blood flow (given the same volume throughput).

### FFT Automatic Gain Control

The FFT (fast Fourier transform) within the Doppler digital processing chain uses a 128-point radix-2 implementation. This breaks down to 64 two-point butterflies on each of seven passes to complete an FFT. After each butterfly, the potential for a bit growth in the data width becomes a reality, resulting from the fact that additions (subtractions) of two  $n$ -bit numbers can yield an  $(n+1)$ -bit number. The input data width starts at eight bits and after seven passes can grow to 15 bits for a pure-tone input in the absence of noise. As such, provision must be made to accommodate the growth.

Several techniques are possible. One can automatically scale the data after every pass, which can incur a dynamic range problem. One can assess whether growth has occurred and, if so, then scale that pass, which incurs additional processing time between passes. One can provide a 15-bit data path through the FFT, which incurs unnecessary processing costs (particularly the multiplier), or one can provide an AGC on the input signal such that overflows that seriously degrade the spectral output are prevented. This last approach is implemented in HP's Doppler FFT processing chain.

Using the specifics of the design, potential overflows can occur during the last three passes of the FFT. With an understanding of the tree structure for FFT processing, it is fairly apparent that overflows occurring during the earlier passes get propagated as processing errors to many more frequency bins than do overflows in later passes.

Stated another way, the overflow problem is less damaging in the later passes. This is the key to the AGC strategy.

The AGC circuitry employs an overflow counter that counts the number of additions (subtractions) that result in a sign-bit error (two's complement arithmetic is used). For example, if two positive (negative) numbers get added with a negative (positive) resulting sign bit, then an overflow has occurred. The overflows are counted for each of the last three passes and stored in latches for processor readback. The individual counts for each of the last four passes are latched. The central processor reads the overflow latches periodically (the AGC time constant) and changes the input front-end gain appropriately. For overflows in an earlier pass, the gain is decreased by  $k$  and then the latches are cleared. When interrogated again, if overflows have been suppressed in that pass and are showing up in the next pass (also in all succeeding passes), the gain is decreased by  $k/2$ . This is in keeping with the fact that overflows in later passes are not as damaging as in the earlier passes. The latches are again cleared and the process is repeated.

Finally, the overflows are driven to the last pass by successively less aggressive AGC control (AGC gain) at which point the gain must now be toggled to maintain the overflows within acceptable bounds. It must be set low enough

so as not to contaminate too many bins in the output, but high enough to see some acceptable number of overflows. This number is the AGC setpoint.

But what keeps the AGC from bringing up the noise floor in the absence of signal? The answer is nothing, since that would be the role of any AGC in an attempt to find a signal. However, if another mechanism is added to the AGC algorithm, this noise pumping can be avoided. Since the variance (the square of the standard deviation) is calculated in the Doppler processing chain, this information can be used in conjunction with the overflows to control the gain. The signal is considered to be noise if the variance is above a predetermined level. If noise as determined by the variance is detected, then the incremental increases in gain for the last pass are suppressed even though the overflows are below the level where gain increases would normally be asked for. In this way the background noise level is prevented from being increased to the point of causing overflows. Only in lower-variance signals is the gain allowed to increase if the overflows are below the selected threshold.

#### Reference

1. L. Schirm IV, "Get to Know the FFT, and Take Advantage of Speedy LSI Building Blocks," *Electronic Design*, Vol. 27, no. 9, April 26, 1979.

Hewlett-Packard Company, 3000 Hanover  
Street, Palo Alto, California 94304

### HEWLETT-PACKARD JOURNAL

June 1986 Volume 37 • Number 6

Technical Information from the Laboratories of  
Hewlett-Packard Company

Hewlett-Packard Company, 3000 Hanover Street  
Palo Alto, California 94304 U.S.A.

Hewlett-Packard Central Mailing Department  
P.O. Box 529, Startbaan 16

1180 AM Amstelveen, The Netherlands

Yokogawa-Hewlett-Packard Ltd., Suginami-Ku Tokyo 168 Japan  
Hewlett-Packard (Canada) Ltd.

6877 Goreway Drive, Mississauga, Ontario L4V 1M8 Canada

Bulk Rate  
U.S. Postage  
Paid  
Hewlett-Packard  
Company

0400094304&&&PONT&G&00  
MR GEORGE PONTIS  
SUITE 409  
1742 SAND HILL RD  
PALO ALTO CA 94304

**CHANGE OF ADDRESS:** To subscribe, change your address, or delete your name from our mailing list, send your request to Hewlett-Packard Journal, 3000 Hanover Street, Palo Alto, CA 94304 U.S.A. Include your old address label, if any. Allow 60 days.